

POTOCOCCO ITALY

20
26

Un catalogo che diventa racconto:
dei nostri prodotti, delle nostre
radici, della nostra identità.

A catalogue that becomes a
tale: of our products, our roots,
and our identity.

45.9859° N
13.3761° E

20
26

potocco.it

45.9859° N
13.3761° E
dal 1919
a Manzano,
Provincia di Udine,
Italia

**20
26**

OS
OS

45.9859° N

13.3761° E
dal 1919

a Manzano,
Provincia di Udine,
Italia

42.9829° N

la nebbia svanisse

le
13.3761° E
dal 1919
a Manzano,
Provincia di Udine,
Italia
fiocchi luccicanti
nel bosco

liberazione d'angeli

E 13.3791° E

la nebbia svanisse

le montagne
dal 1919
a Manzano,
Provincia di Udine,
Italia
fiocchi luccicanti
nel bosco

liberazione d'angeli

All'alba¹

dal 1919
a Manzano,
Provincia di Udine,
Italia

se la nebbia svanisse
al centro delle parole
e l'occhio balzasse
oltre le montagne
se facce di mercanti
sprofondassero in riflessi
di vetri frantumati
fili e focchi luccicanti
un suono nel bosco
sveglierebbe nascosti amori
oh se la nebbia sparisse
e sgorgasse luce
liberazione d'angeli
sepolti tra mille scorie

Luciano Morandini

All'alba¹

se la nebbia svanisse
al centro delle parole
e l'occhio balzasse
oltre le montagne
se facce di mercanti
sprofondassero in riflessi
di vetri frantumati
fili e fiocchi luccicanti
un suono nel bosco
sveglierebbe nascosti amori
oh se la nebbia sparisse
e sgorgasse luce
liberazione d'angeli
sepolti tra mille scorie

Luciano Morandini



Vedute storiche della fabbrica di
Manzano, cuore delle nostre radici.

Historical views of the Manzano
factory, the heart of our heritage.

Circa 1956





Graffietto.
Usato per segnare il legno.
Wood-marking utensil.



Saracco.
Seghetto per il legno.
Narrow-blade saw for wood cutting.



Martello in gomma.
Usato per il montaggio.
Used during assembly work.

Petalus.
Stadium.
Stadium Cane.
Velvet.
Canyons.
Eline.
Orlea.
Kira.
Side by Side.
Jade.
Softy.
Velis.
Stilla.

Tressa.
Side by Side.
Solar.
Jade.

Architect & Friends.
Chiara Andreatti.
Favaretto&Partners.
Hanne Willmann.
Mario Ferrarini.
Potocco D&D.
Serena Confalonieri.
Studio Omi Tahara.
Vladislav Tolochko.

Materials.
Coverings.

Indoor

Petalus. 025

Poltrona Lounge. Lounge Armchair.
Sofa. 2 Posti. 2 Seater.
Sofa. 3 Posti. 3 Seater.
Sofa. Moduli. Modules.
Tavolino. Insert.

Stadium. 043

Sedia Dining. Dining Chair.
Poltroncina Dining. Dining Armchair.
Poltrona Lounge. Lounge Armchair.

Stadium Cane. 053

Sedia Dining. Dining Chair.
Poltroncina Dining. Dining Armchair.
Poltrona Lounge. Lounge Armchair.

Velvet. 065

Sedia Dining. Dining Chair.
Poltroncina Dining. Dining Armchair.

Canyons. 073

Madia. 2 Moduli. Sideboard. 2 Modules.
Madia. 3 Moduli. Sideboard. 3 Modules.
Madia. 3 Moduli. Sideboard. 3 Modules.
Madia. 3 Moduli. Sideboard. 3 Modules.
Madia. 4 Moduli. Sideboard. 4 Modules.
Madia. Moduli. Sideboard. Modules.

Eline. 093

Poltroncina Dining. Dining Armchair.

Orlea. 099

Tavolino Circolare. Circular Coffee Table.
Tavolino Ellittico. Elliptical Coffee Table.

Kira. 111

Tavolo Circolare. Circular Table.
Tavolo A Botte. Barrel Table.

Side By Side. 121

Tavolo Rettangolare. Rectangular Table.
Tavolo Circolare. Circular Table.
Tavolino Circolare. Circular Coffee Table.
Tavolino Ellittico. Elliptical Coffee Table.

Jade. 133

Letto. Bed.

Softy. 141

Sedia Dining. Dining Chair.
Sgabello Up & Down. Up & Down Stool.

Velis. 149

Poltroncina Pozzetto. Tub Chair.

Stilla. 155

Specchio Circolare. Circular Mirror.
Specchio Esagonale. Hexagonal Mirror.

Petalus.

By Favaretto&Partners

Poltrona Lounge. Lounge Armchair.
Sofa. 2 Posti. 2 Seater.
Sofa. 3 Posti. 3 Seater.
Sofa. Moduli. Modules.

Disegnata da Favaretto&Partners, la collezione Petalus comprende poltrona e divano modulare, imbottiti e completamente sfoderabili. Il progetto si distingue per il caratteristico bracciolo a forma di petalo, da cui prende il nome, e per le sue proporzioni ampie e affusolate. La poltrona, con la sua silhouette leggermente sollevata alle estremità, trasmette morbidezza e leggerezza trasformando la seduta in un gesto avvolgente di relax. Il divano modulare riprende lo stesso linguaggio, con elementi lineari e angolari componibili che enfatizzano il senso di accoglienza.

Designed by Favaretto&Partners, the Petalus collection comprises an armchair and a modular sofa, both upholstered and fully removable. The collection is defined by its distinctive petal-shaped armrest, from which it takes its name, and by generous yet refined proportions. The armchair, with a silhouette that subtly lifts at the ends, conveys a sense of softness and lightness, turning seating into an enveloping gesture of relaxation. The modular sofa reflects the same design language, featuring linear and corner elements that can be freely combined to enhance a feeling of comfort and hospitality.

Petalus. Poltrona Lounge.
Lounge Armchair.



Petalus Lounge Armchair
629/PL
uph. Aida Beige A2E.

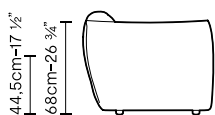
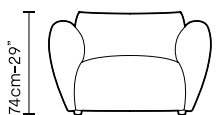
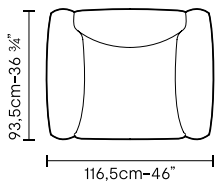

**Petalus. Sofa. 2 Posti.
2 Seater.**



Petalus 2 Seater Sofa
629/DT-DX, 629/DT-SX
uph. Aida Beige A2E.

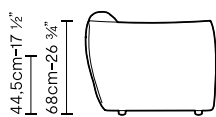
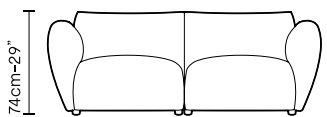
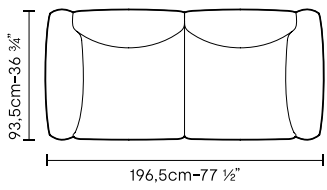

Petalus. Sofa. 3 Posti.
3 Seater.



Petalus 3 Seater Sofa
629/DT-DX, 629/DM, 629/DT-SX
uph. Aida Beige A2E.

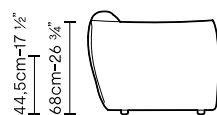
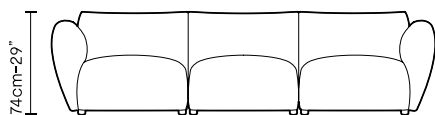
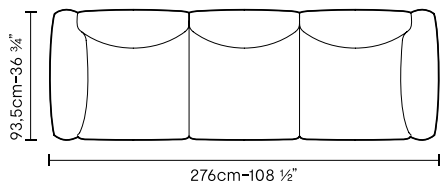



Petalus 3 Seater Sofa
629/DT-DX, 629/DM, 629/DT-SX
uph. Aida Beige A2E.

**Petalus. Sofa. Moduli.
Modules.**

Petalus Modular Sofa
629/DT-DX, 629/TB, 629/DM,
629-D-ANG-45, 629/DT-SX, 629/O
uph. Aida Beige A2E.



Petalus. Sofa. Moduli. Modules.

Modulo Angolare. Corner Unit
629/D-ANG-90

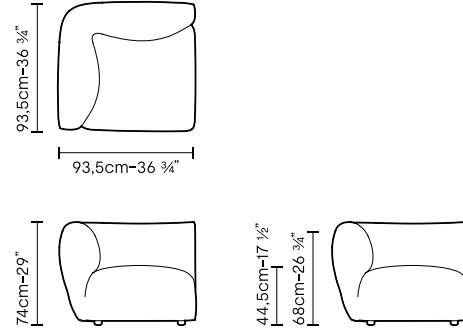

Modulo Finale Destro. Right Side Unit
629/DT-DX

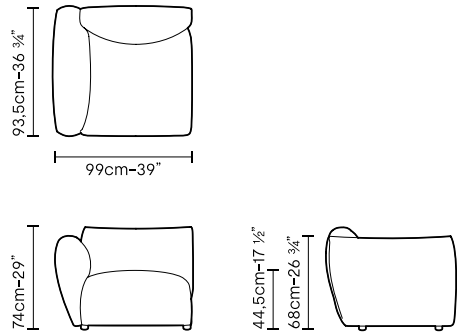

Modulo Triangolare. Triangular Unit
629/D-ANG-45

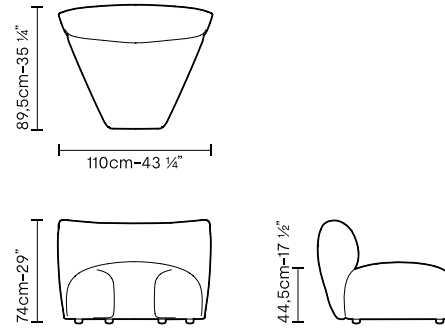

Modulo Finale Sinistro. Left Side Unit
629/DT-SX

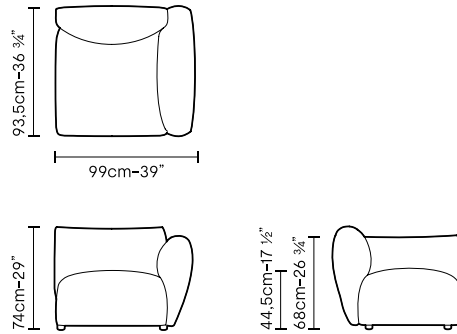

Pouf. Pouf
629/O

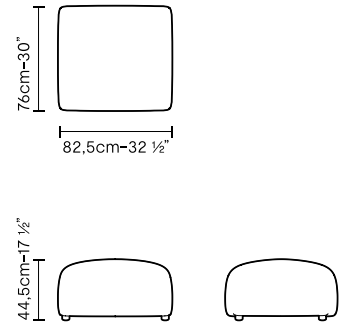

Modulo Centrale. Central Unit
629/DM

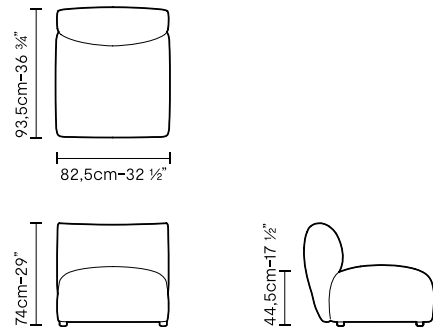

Tavolino. Insert
629/TB

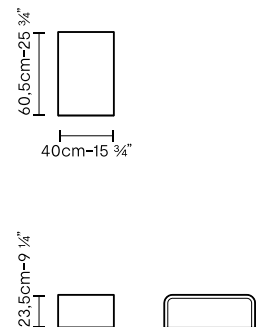



Petalus Modular Sofa
629/DT-DX, 629/DM, 629/TB,
629-D-ANG-90, 629/DT-SX, 629/O
uph. Aida Beige A2E.

Petalus. Finiture. Finishes.

Collezione composta da poltrona e divano modulare imbottiti e sfoderabili disponibili nei rivestimenti a collezione. Esplora tutte le finiture pag. 250

Collection composed of an upholstered armchair and a modular sofa, both fully removable and available in the upholstery options of the collection. Explore all the finishes pag. 250

Petalus Modular Sofa
629/DT-DX, 629/DM, 629/TB,
629-D-ANG-90, 629/DT-SX, 629/O
uph. Aida Beige A2E.



Stadium. By Favaretto&Partners

Sedia Dining. Dining Chair.
Poltroncina Dining. Dining Armchair.
Poltrona Lounge. Lounge Armchair.

La collezione Stadium, progettata da Favaretto&Partners, comprende sedia, poltroncina e poltrona lounge, tutte con struttura in massello di frassino e seduta imbottita che valorizzano l'artigianalità Potocco. Protagonista è lo schienale che disegna una curva ellittica in continuità con i braccioli, evocando il gesto di un abbraccio. La seduta dialoga con lo schienale per offrire versatilità e comfort. La poltrona lounge, con le sue proporzioni ampie, accentua la presenza materica e la fluidità della silhouette.

Designed by Favaretto&Partners, the Stadium collection includes a dining chair and armchair, and lounge armchair, all featuring a solid ash wood frame and an upholstered seat that highlights Potocco's artisanal craftsmanship. At the forefront is the backrest, which traces an elliptical curve seamlessly extending into the armrests, evoking the gesture of an embrace. The seat interacts harmoniously with the backrest to ensure versatility and comfort, while the lounge armchair, with its generous proportions, emphasizes the material presence and fluidity of the silhouette.

Stadium. Sedia Dining.
Dining Chair.



Stadium Dining Chair
599/1
Carbon stained solid ash wood frame,
uph. Galea Nero C4F.

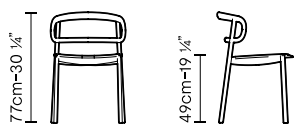

Stadium. Poltroncina Dining.
Dining Armchair.



Stadium Dining Armchair
599/PI
Carbon stained solid ash wood frame,
uph. Galea Nero C4F.

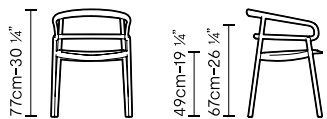
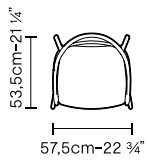

Stadium. Poltrona Lounge.
Lounge Armchair.



Stadium Lounge Armchair
599/PLI
Carbon stained solid ash wood frame,
uph. Galea Nero C4F.

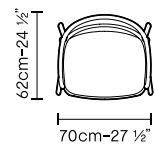

Stadium. Finiture. Finishes.

Collezione composta da sedia e poltroncina dining e poltrona lounge con struttura in frassino nelle tinte a collezione e seduta imbottita disponibile nei rivestimenti a collezione. Esplora tutte le finiture pag. 250

Collection composed of a dining chair, a dining armchair, and a lounge armchair with an ash wood frame in the finishes of the collection, and an upholstered seat available in the upholstery options of the collection. Explore all the finishes pag. 250

Stadium Lounge Armchair
599/PLI
Carbon stained solid ash wood frame,
uph. Galea Nero C4F.



Stadium Cane.

By Favaretto&Partners

Sedia Dining. Dining Chair.
Poltroncina Dining. Dining Armchair.
Poltrona Lounge. Lounge Armchair.

La collezione di sedute Stadium, disegnata da Favaretto&Partners, si amplia con la versione Cane introducendo lo schienale con inserto in canna naturale. La struttura in massello di frassino valorizza la qualità artigianale del legno e crea un segno continuo e armonico, dove la curva dello schienale accompagna i braccioli in un gesto fluido. La trama leggera della canna intrecciata genera un raffinato contrasto tra rigore costruttivo e trasparenza visiva, mentre la seduta imbottita completa la composizione offrendo un'esperienza sensoriale di comfort.

The Stadium seating collection, designed by Favaretto&Partners, expands with the Cane version, introducing a backrest featuring a natural cane insert. The solid ash wood frame enhances its artisanal quality, creating a continuous and harmonious silhouette where the curvature of the backrest flows seamlessly into the armrests. The lightweight woven cane texture establishes a refined contrast between structural precision and visual transparency, while the upholstered seat completes the composition, offering a sensorial experience of comfort.

Stadium Cane. Sedia Dining.
Dining Chair.



Stadium Cane Dining Chair

599/CI

Beige stained solid ash wood frame,
beige stained cane backrest,
uph. Bliss Beige HIZ.

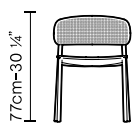
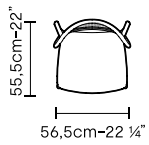



Stadium Cane Dining Chair

599/C1

Beige stained solid ash wood frame,
beige stained cane backrest,
uph. Bliss Beige H1Z.



Stadium Cane. Poltroncina Dining.
Dining Armchair.



Stadium Cane Dining Armchair

599/PCI

Beige stained solid ash wood frame,
beige stained cane backrest,
uph. Bliss Beige HIZ.

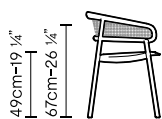
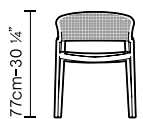
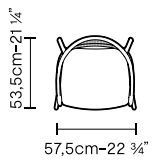

Stadium Cane. Poltrona Lounge.
Lounge Armchair.



Stadium Cane Lounge Armchair

599/PLCI

Beige stained solid ash wood frame,
beige stained cane backrest,
uph. Bliss Beige HIZ.

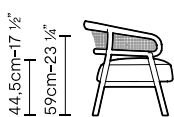
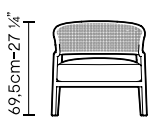
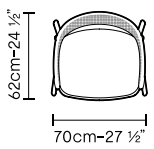

Stadium Cane. Finiture. Finishes.

Collezione composta da sedia e poltroncina dining e poltrona lounge con struttura in frassino nelle tinte a collezione, schienale con inserto in canna naturale e nelle tinte a collezione e seduta imbottita disponibile nei rivestimenti a collezione. Esplora tutte le finiture pag. 250

Collection composed of a dining chair, a dining armchair, and a lounge armchair with an ash wood frame in the finishes of the collection; backrest featuring a natural cane insert, available in natural finish or in the finishes of the collection; upholstered seat available in the upholstery options of the collection. Explore all the finishes pag. 250

Stadium Cane Lounge Armchair
599/PLCI
Beige stained solid ash wood frame,
beige stained cane backrest,
uph. Bliss Beige H1Z.



Velvet.

By Mario Ferrarini

Sedia Dining. Dining Chair.
Poltroncina Dining. Dining Armchair.

Firmata da Mario Ferrarini, Velvet è una collezione composta da sedia e poltroncina dining che coniuga minimalismo compositivo e raffinata attenzione al dettaglio. La struttura, realizzata in massello di frassino, si distingue per il disegno dinamico delle gambe. Da una sezione affusolata si aprono in una morbida bombatura per poi assottigliarsi nuovamente lanciando la silhouette. Lo schienale imbottito è caratterizzato da una conformazione ampia e fortemente avvolgente, studiata per garantire comfort ergonomico e continuità formale.

Designed by Mario Ferrarini, Velvet is a collection of dining chairs and armchairs that combines compositional minimalism with refined attention to detail. Crafted from solid ash, the structure is distinguished by the dynamic design of the legs, which transition from a tapered section to a soft curvature before narrowing again, elongating the silhouette. The upholstered backrest features a wide, enveloping profile, conceived to ensure ergonomic comfort and formal continuity.

Velvet. Sedia Dining.
Dining Chair.



Velvet Dining Chair
899
Carbon stained solid ash wood frame,
uph. Baldo Avorio B7C.

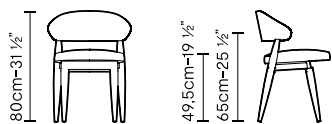
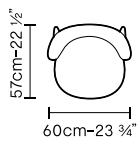

Velvet. Poltroncina Dining.
Dining Armchair.



Velvet Dining Armchair
899/P
Beige stained solid ash wood frame,
uph. Baldo Beige B7B.

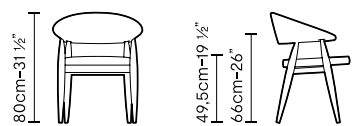
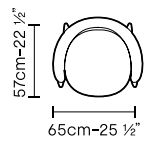

Velvet. Finiture. Finishes.

Collezione composta da sedia e poltroncina dining con struttura in frassino nelle finiture a collezione e seduta e schienale imbottiti disponibili nei rivestimenti a collezione. Esplora tutte le finiture pag. 250

Collection composed of a dining chair and a dining armchair with an ash wood frame in the finishes of the collection, and upholstered seat and backrest available in the upholstery options of the collection. Explore all the finishes pag. 250

Velvet Dining Armchair
899/P
Beige stained solid ash wood frame,
uph. Baldo Beige B7B.



Velvet Dining Chair
899
Carbon stained solid ash wood frame,
uph. Baldo Avorio B7C.



Canyons.

By Studio Omi Tahara

Madia. 2 Moduli. Sideboard. 2 Modules.
Madia. 3 Moduli. Sideboard. 3 Modules.
Madia. 3 Moduli. Sideboard. 3 Modules.
Madia. 3 Moduli. Sideboard. 3 Modules.
Madia. 4 Moduli. Sideboard. 4 Modules.
Madia. Moduli. Sideboard. Modules.

La madia Canyons, disegnata da Studio Omi Tahara per Potocco, è un sistema modulare composto da elementi di diverse forme e larghezze. La struttura è realizzata in frassino con ante disponibili in frassino, laccate o impiallacciate in decorativo radica. La composizione dei moduli consente configurazioni flessibili, pensate per adattarsi con naturalezza allo spazio. Il concept nasce da una riflessione su forma e percezione: come in un canyon, le superfici inclinate generano variazioni di profondità e un ritmo visivo dinamico.

Designed by Studio Omi Tahara for Potocco, the Canyons sideboard is a modular system composed of elements in different shapes and widths. The structure is crafted from ash, with doors available in ash wood, lacquered finishes, or veneered with decorative burl wood. The composition of the modules allows for flexible configurations, conceived to adapt naturally to a variety of spaces. The concept stems from a reflection on form and perception: much like a canyon, the inclined surfaces create subtle variations in depth, generating a dynamic visual rhythm.

Canyons. Madia. 2 Moduli.
Sideboard. 2 Modules.



Canyons Sideboard
586/MST-SX, 586/MLT-DX
Wengé stained solid ash wood frame,
matt burl wood doors.

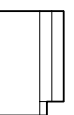
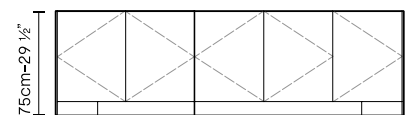
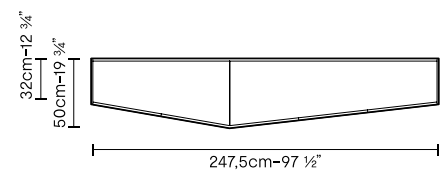

Canyons. Madia. 3 Moduli.
Sideboard. 3 Modules.



Canyons Sideboard
586/MLT-SX, 586/MM 50, 586/MST-DX
Dark grey stained solid ash wood frame,
glossy lacquered ash wood doors RAL 7022.

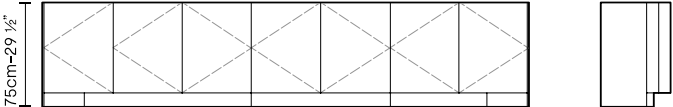
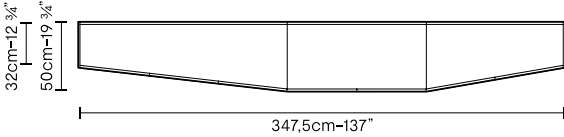



Canyons Sideboard
586/MLT-SX, 586/MM-50, 586/MST-DX
Dark grey stained solid ash wood frame,
glossy lacquered ash wood doors RAL 7022.

Canyons. Madia. 3 Moduli.
Sideboard. 3 Modules.



Canyons Sideboard
586/MLT-SX, 586/MM-32
Biscuit stained solid ash wood frame and doors.

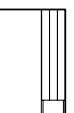
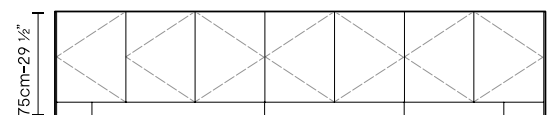
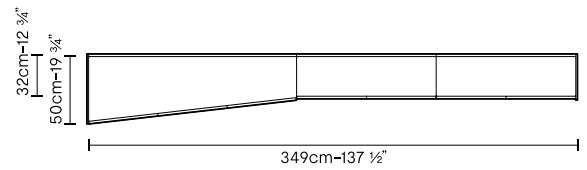

Canyons. Madia. 3 Moduli.
Sideboard. 3 Modules.



Canyons Sideboard
586/MLT-SX, 586/MM-32
Biscuit stained solid ash wood frame and doors.

Canyons. Madia. 3 Moduli.
Sideboard. 3 Modules.



Canyons Sideboard
586/MLT-SX, 586/MM-50, 586/MLT-DX
White stained solid ash wood frame,
glossy lacquered ash wood doors RAL 1013.

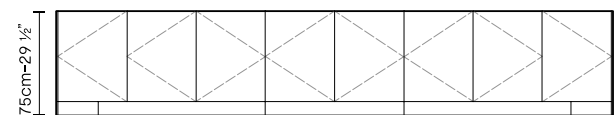
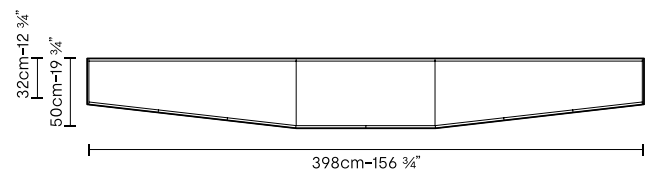

Canyons. Madi. 4 Moduli.
Sideboard. 4 Modules.



Canyons Sideboard
586/MST-SX, 586/MM-50, 586/MLT-DX
Wengé stained solid ash wood frame,
matt burl wood doors.

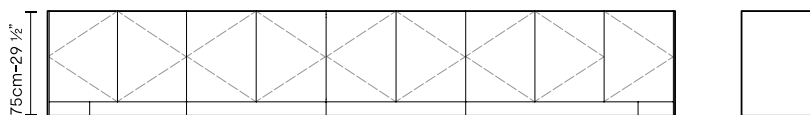
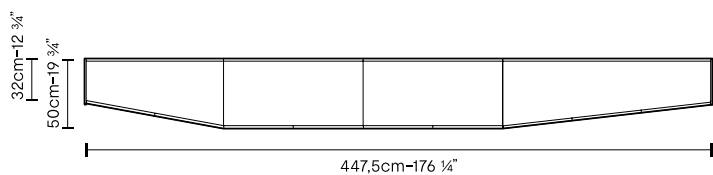

Canyons. Madia. Moduli. Modules.

Modulo Finale Corto. Short Side Unit
586/MST-SX

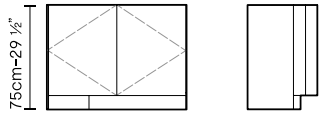
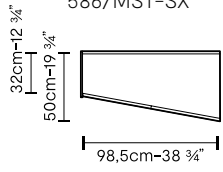

Modulo Finale Corto. Short Side Unit
586/MST-DX

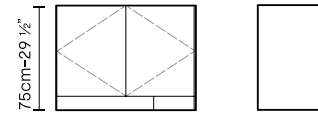
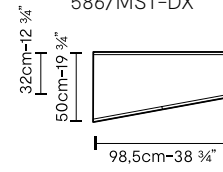

Modulo Finale Lungo. Long Side Unit
586/MLT-SX

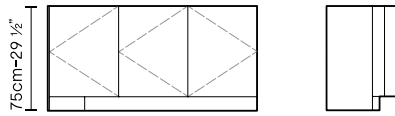
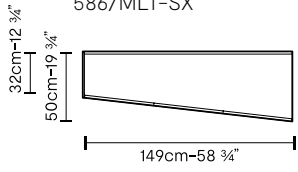

Modulo Finale Lungo. Long Side Unit
586/MLT-DX

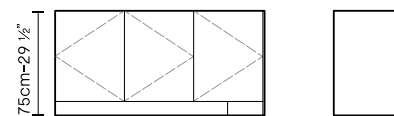
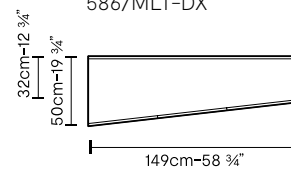

Modulo Centrale. Central Unit
586/MM-50

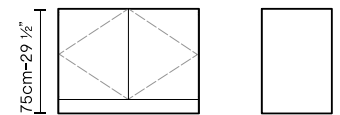
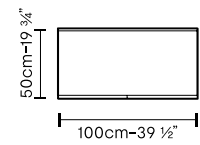

Modulo Centrale. Central Unit
586/MM-32

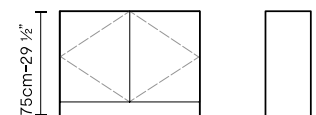
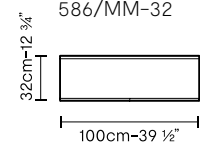

Canyons. Finiture. Finishes.

Collezione di madie componibili e modulari con struttura in frassino e con ante laccate nei colori ral, in frassino nelle tinte a collezione o impiallacciate in decorativo radica. Esplora tutte le finiture pag. 248

Collection of modular and configurable sideboards with an ash wood structure and doors available in RAL lacquered finishes, ash wood in the finishes of the collection, or veneered with decorative burl wood. Explore all the finishes pag. 248

Canyons Sideboard
586/MST-SX, 586/MM-50, 586/MLT-DX
Wengé stained solid ash wood frame,
matt burl wood doors.



Eline.

By Architect & Friends

Poltroncina Dining. Dining Armchair.

Disegnata da Architect & Friends per Potocco, la poltroncina Eline si distingue per la struttura in legno che definisce con continuità gambe e braccioli, accogliendo una seduta ampia con schienale e seduta interamente imbottiti. Il design si distingue per la cura dei dettagli: il bracciolo richiama la linea essenziale della lama di un coltello tipicamente utilizzato nelle cucine, mentre la fascia posteriore che sostiene lo schienale introduce un segno grafico deciso.

Designed by Architect & Friends for Potocco, the Eline dining armchair is distinguished by its wooden structure, which seamlessly defines the legs and armrests while embracing a generously proportioned seat with a fully upholstered backrest and cushion. The design is characterized by a refined attention to detail: the armrest recalls the essential line of a knife blade commonly found in the kitchen, while the rear band supporting the backrest introduces a bold graphic element.

Eline. Poltroncina Dining.
Dining Armchair.



Eline Dining Armchair
849/P
Carbon stained solid ash wood frame,
hide leather Nero BM,
uph. Baldo Avorio B7C.

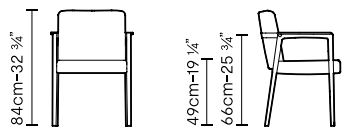
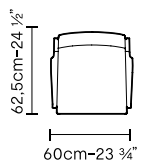

Eline. Finiture. Finishes.

Collezione composta da poltroncina dining con struttura in frassino nelle tinte a collezione e sedile e schienali imbottiti disponibili nei rivestimenti a collezione; dettaglio dello schienale in cuoietto nelle tinte a collezione e bottoni in ottone. Esplora tutte le finiture pag. 248

Collection composed of a dining armchair with an ash wood frame in the finishes of the collection, and upholstered seat and backrest available in the upholstery options of the collection; backrest detail in hide leather in the finishes of the collection with a brass button. Explore all the finishes pag. 248

Eline Dining Armchair
849/P
Carbon stained solid ash wood frame,
hide leather Nero BM,
uph. Baldo Avorio B7C.



Orlea.

By Chiara Andreatti

Tavolino Circolare. Circular Coffee Table.
Tavolino Ellittico. Elliptical Coffee Table.

Orlea è una collezione di coffee table in marmo disegnata da Chiara Andreatti, caratterizzata da una stabilità compositiva tra presenza scultorea e raffinatezza dei dettagli. La struttura è definita dalle gambe coniche leggermente bombate che conferiscono stabilità e sottigliezza formale, creando un segno distintivo e riconoscibile. Il piano realizzato in marmo è impreziosito da un bordo dentellato che introduce un sottile dettaglio decorativo.

Orlea is a collection of marble coffee tables designed by Chiara Andreatti, defined by a refined balance between sculptural presence and meticulous detailing. The structure features subtly rounded conical legs that lend both stability and a sense of formal lightness, creating a distinctive and recognizable signature. The marble top is enriched by a delicately notched edge, introducing a subtle decorative accent.

Orlea. Tavolino Circolare.
Circular Coffee Table.



Orlea Circular Coffee Table
598/TBC
Nero Marquina marble base,
White Carrara marble top.

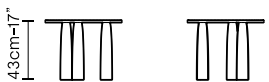
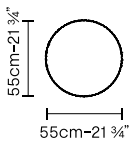



Orlea Circular Coffee Table
598/TBC
Nero Marquina marble base,
White Carrara marble top.

Orlea. Tavolino Ellittico.
Elliptical Coffee Table.



Orlea Elliptical Coffee Table
598/TBE
White Carrara marble base,
Nero Marquinia marble top.

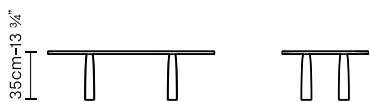
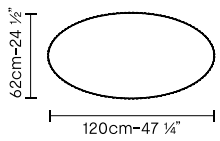



Orlea Elliptical Coffee Table
598/TBE,
White Carrara marble base and top.

Orlea Circular Coffee Table
598/TBC,
Nero Marquina marble base and top.

Orlea. Finiture. Finishes.

Collezione di tavolini in due forme e altezze disponibili nei marmi Bianco Carrara e Nero Marquinia. Disponibili nella configurazione monomaterica e bimaterica. Esplora tutte le finiture pag. 250

Collection of coffee tables available in two shapes and heights, offered in Bianco Carrara and Nero Marquinia marble. Available in monomaterial and bimaterial configurations. Explore all the finishes pag. 250

Orlea Elliptical Coffee Table
598/TBE
White Carrara marble base,
Nero Marquinia marble top.



Kira.

By Chiara Andreatti

Tavolo Circolare. Circular Table.
Tavolo A Botte. Barrel Table.

Dalla visione progettuale di Chiara Andreatti nasce Kira, una collezione di tavoli dining definita da una presenza solida e da un linguaggio formale essenziale. Le gambe - realizzate in massello di frassino scolpito - sono segnate da delicati cambi di sezione che conferiscono al tavolo un carattere scultoreo, e raccordate da un elemento in ottone brunito, ad aggiungere stabilità e un segno decorativo all'oggetto. Il piano circolare o a botte è pensato per valorizzare la matericità dei materiali e la purezza delle proporzioni.

Born from the design vision of Chiara Andreatti, Kira is a dining table collection defined by its solid presence and essential formal language. The legs, crafted from sculpted solid ash, feature subtle shifts in section that lend the table a sculptural character, while a bronzed-brass connector enhances stability and introduces a refined decorative accent. The circular or barrel-shaped top is conceived to highlight the material richness and purity of its proportions.

Kira. Tavolo Circolare.
Circular Table.



Kira Circular Table
588/TC
White stained solid ash wood base,
White Carrara marble top,
bronzed brass base connection.

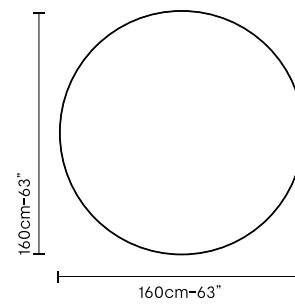



Kira Circular Table
588/TC
White stained solid ash wood base,
White Carrara marble top,
bronzed brass base connection.

Kira. Tavolo A Botte.
Barrel Table.



Kira Barrel Table
588/TO
Carbon stained solid ash wood base and top,
bronzed brass base connection.

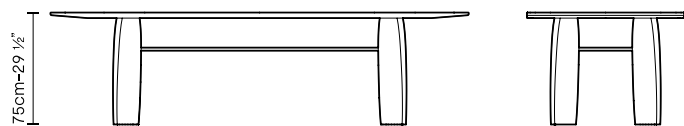
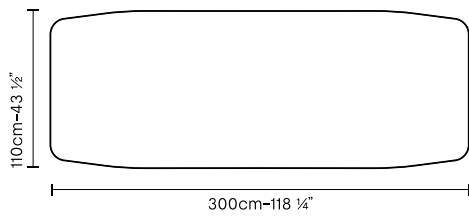

Kira. Finiture. Finishes.

Collezione di tavoli dining con base in frassino nelle finiture a collezione e piano in frassino o marmo nelle finiture a collezione per la versione circolare, piano in frassino nelle finiture a collezione per la versione a botte; raccordo tra le basi in ottone brunito. Esplora tutte le finiture pag. 250

Dining table collection with an ash wood base in the finishes of the collection; top in ash wood or marble in the finishes of the collection for the round version, and ash wood top in the finishes of the collection for the barrel-shaped version; connecting element between the bases in bronzed brass. Explore all the finishes pag. 250

Kira Barrel Table
588/TO
Carbon stained solid ash wood base and top,
bronzed brass base connection.



Side by Side. By Potocco D&D

Tavolo Rettangolare. Rectangular Table.
Tavolo Circolare. Circular Table.
Tavolino Circolare. Circular Coffee Table.
Tavolino Ellittico. Elliptical Coffee Table.

La collezione Side by Side disegnata dal gruppo D&D di Potocco comprende tavoli e tavolini. La base, che riprende la forma di un parallelepipedo irregolare, è rivestita da listelli di vetro a tinta unita o multicolore. I listelli di vetro, disposti in geometrie variabili, catturano e rifrangono la luce, trasformando ogni elemento in un oggetto scultoreo e architettonico. I coffee table sono disponibili con piano circolare o ellittico mentre i tavoli da pranzo propongono piani rettangolari o circolari con proporzioni calibrate e leggerezza visiva.

Designed by Potocco's D&D group, the Side by Side collection includes tables and coffee tables. The base, echoing the form of an irregular parallelepiped, is covered with solid-color or multicolored glass slats. Arranged in varying geometries, the glass slats capture and refract light, transforming each piece into a sculptural and architectural object. The coffee tables are available with circular or elliptical tops, while the dining tables feature rectangular or circular tops, defined by calibrated proportions and visual lightness.

Side by Side. Tavolo Rettangolare.
Rectangular Table.



Side by Side Rectangular Table
703/TR
Liquirizia lacquered metal base plate,
Liquirizia back-painted glass slats base,
Liquirizia back-painted glass top.

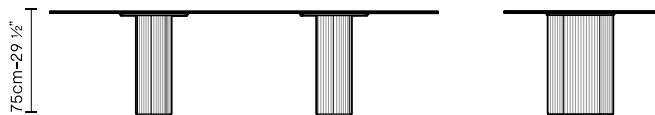
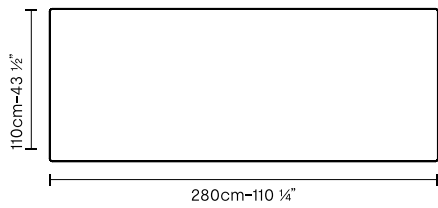

Side by Side. Tavolo Circolare.
Circular Table.



Side By Side Circular Table
703/TC
Amarena lacquered metal base plate,
Amarena back-painted glass slats base,
Amarena back-painted glass top.

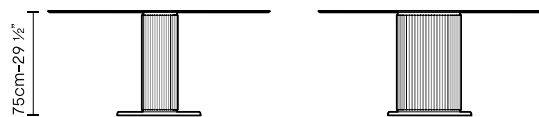
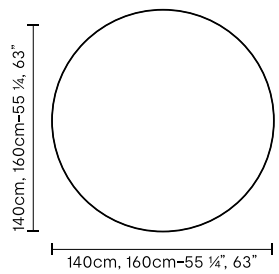



Side By Side Circular Table

703/TC

Amarena lacquered metal base plate,
Amarena back-painted glass slats base,
Amarena back-painted glass top.

Side by Side. Tavolino Circolare.
Circular Coffee Table.

Tavolino Ellittico.
Elliptical Coffee Table.



Tavolino Circolare. Circular Coffee Table
703/TBC

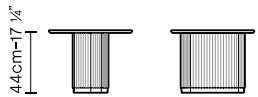
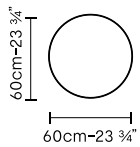

Tavolino Ellittico. Elliptical Coffee Table
703/TBE

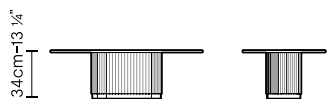
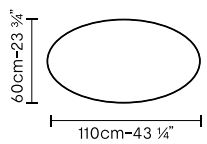

Side By Side Circular Coffee Table
703/TBC

Side By Side Elliptical Coffee Table
703/TBE

Liquirizia lacquered metal base plate,
Liquirizia back-painted glass slats base,
carbon stained solid ash wood top.

Side by Side. Finiture. Finishes.

Collezione di tavoli e tavolini in diverse forme e altezze con struttura rivestita da listelli di vetro tinta unita o multi-colore e piano disponibile in vetro o frassino nelle tinte a collezione. Esplora tutte le finiture pag. 250

Collection of tables and coffee tables available in various shapes and heights, featuring a structure clad in solid-color or multicolored glass slats, and a top available in glass or ash wood in the finishes of the collection. Explore all the finishes pag. 250

Side By Side Circular Coffee Table

703/TBC

Side By Side Elliptical Coffee Table

703/TBE

Liquirizia lacquered metal base plate,
Liquirizia back-painted glass slats base,
carbon stained solid ash wood top.



Jade.

By Hanne Willmann

Letto. Bed.

La collezione Jade di Hanne Willmann, definita da profili sinuosi, si amplia con un nuovo elemento, il letto, portando le sue forme organiche e avvolgenti dal living alla zona notte. Caratterizzato da una testata generosa dai dettagli arrotondati, Jade è completamente imbottito e sfoderabile. La sua presenza elegante e sofisticata traspone i canoni formali e distintivi della collezione a un nuovo contesto.

Hanne Willmann's Jade collection, defined by sinuous profiles, expands with a new element—the bed—bringing its organic, enveloping forms from the living area into the sleeping space. Featuring a generous headboard with softly rounded detailing, Jade is fully upholstered and completely removable. Its elegant and sophisticated presence seamlessly translates the collection's distinctive formal language into a new context.

Jade. Letto. Bed



Jade Bed
953/BED
uph. Cortina Sabbia A9R.

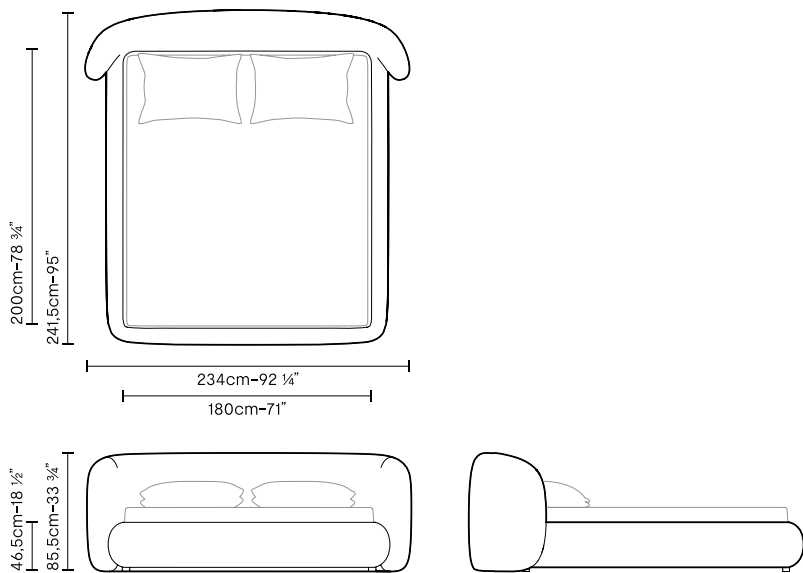

Jade. Letto.
Bed



Jade Bed
953/BED
uph. Cortina Sabbia A9R.

Jade. Finiture. Finishes.

Struttura del letto imbottita e sfoderabile disponibile nei rivestimenti elastici a collezione. Esplora tutte le finiture pag. 250

Upholstered and fully removable bed frame, available in the elastic upholstery options of the collection. Explore all the finishes pag. 250



Softy.

By Vladislav Tolochko

Sedia Dining. Dining Chair.
Sgabello Up & Down. Up & Down Stool.

La collezione Softy, disegnata da Vladislav Tolochko, si amplia grazie all'aggiunta di sedia e sgabello che confermano il linguaggio sinuoso e i volumi importanti del progetto. Nella sedia, i profili si fanno più slanciati ma mantengono la rotondità formale della lounge, mentre le gambe cilindriche seguono la silhouette della seduta e risalgono lungo lo schienale, creando un segno continuo e riconoscibile. Lo sgabello affianca alla morbidezza di seduta e schienale il rigore della base in metallo con meccanismo up&down.

The Softy collection, designed by Vladislav Tolochko, expands with the addition of a dining chair and a stool that reaffirm the project's sinuous language and generous volumes. In the chair, the profiles become more slender while retaining the formal roundness of the lounge version; the cylindrical legs follow the silhouette of the seat and rise along the backrest, creating a continuous and recognizable line. The stool combines the softness of the upholstered seat and backrest with the structural rigor of a metal base featuring an up-and-down mechanism.

Softy. Sedia Dining.
Dining Chair.



Softy Dining Chair
959
uph. Dolly Avorio Q2B.

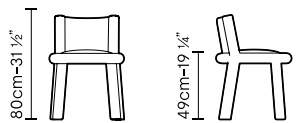
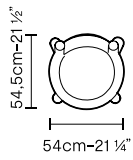

Softy. Sgabello Up & Down.
Up & Down Stool.



Softy Up & Down Stool
959/A-GAS
black chrome base,
uph. Dolly Tortora Q2C.

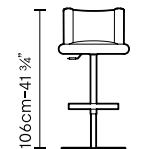
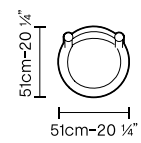

Softy. Finiture Finishes.

Collezione composta da seduta dining interamente imbottita e sgabello con seduta imbottita e base up&down in metallo. Imbottitura disponibile nei rivestimenti elastici a collezione. Esplora tutte le finiture pag. 250

Collection composed of a fully upholstered dining chair and a stool with an upholstered seat and a metal up-and-down base. Upholstery is available in the collection's elastic fabrics. Explore all the finishes pag. 250

Softy Up & Down Stool
959/A-GAS
black chrome base,
uph. Dolly Tortora Q2C.



Velis.

By Mario Ferrarini

Poltroncina Pozzetto. Tub Chair.

La famiglia di sedute Velis, firmata da Mario Ferrarini, si arricchisce con la poltroncina a pozzetto completamente imbottita, dallo schienale fino alle gambe, che ne accentua il valore tattile e sensoriale. La struttura interna sostiene lo schienale e la seduta, conferendo stabilità al progetto. Questa versione di Velis si distingue per l'equilibrio tra assetto formale e comfort, dove la qualità dei materiali e la cura dei dettagli si traducono in un'esperienza di seduta raffinata e misurata.

The Velis seating family, designed by Mario Ferrarini, grows with the addition of a fully upholstered tub chair, covered from the backrest to the legs to enhance its tactile and sensorial qualities. The internal structure supports both backrest and seat, ensuring stability and balance throughout the design. This version of Velis stands out for its equilibrium between formal clarity and comfort, where refined materials and meticulous detailing translate into a measured, sophisticated seating experience.

Velis. Poltroncina Pozzetto.
Tub Chair.



Velis Tub Chair
942/PAI
uph. Dolly Avorio Q2B.

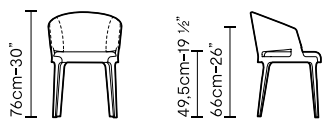
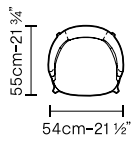

Velis. Finiture Finishes.

Seduta interamente imbottita disponibile nei rivestimenti a collezione. Esplora tutte le finiture pag. 250

Fully upholstered seat, available in the upholstery options of the collection. Explore all the finishes pag. 250

Velis Tub Chair
942/PAI
uph. Dolly Avorio Q2B.



Stilla.

By Serena Confalonieri

Specchio Circolare. Circular Mirror.

Specchio Esagonale. Hexagonal Mirror.

Stilla è una collezione di specchi a parete progettata da Serena Confalonieri che – a partire dalla forma originaria ispirata ai pendenti in cristallo e al taglio a goccia delle pietre preziose – si amplia introducendo nuove varianti nelle geometrie circolare ed esagonale allungata. Il disegno di Stilla coniuga sensibilità decorativa e chiarezza compositiva: la cornice e l'elemento di fissaggio sono rivestiti in pelle, mentre i tubolari di raccordo in metallo, con finitura ottone brunito, scandiscono l'insieme con un segno preciso e misurato.

Stilla is a collection of wall mirrors designed by Serena Confalonieri that, starting from an original form inspired by crystal pendants and the teardrop cut of precious stones, expands with new variants in circular and elongated hexagonal geometries. The design of Stilla combines decorative sensibility with compositional clarity: the frame and mounting element are clad in leather, while the connecting metal tubes, finished in bronzed brass, articulate the composition with a precise and measured gesture.

Stilla. Specchio Circolare.
Circular Mirror.



Stilla Circular Mirror
890/SC
Bronzed brass details,
uph. Galea Tortora chiaro C4T.

65,5cm-25 3/4"

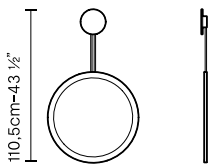

Stilla. Specchio Esagonale.
Hexagonal Mirror.



Stilla Hexagonal Mirror
890/SE
Bronzed brass details,
uph. Galea Nero C4F.

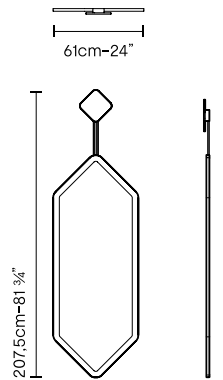

Stilla. Finiture Finishes.

Collezione di specchi a parete disponibili nella forma circolare ed esagonale con cornice ed elemento di fissaggio rivestiti nelle pelli a collezione. Tubolari di raccordo in metallo finitura ottone brunito. Esplora tutte le finiture pag. 248

Collection of wall mirrors available in circular and hexagonal shapes, featuring a frame and mounting element upholstered in the leathers from the collection. Connecting tubular elements in metal with a bronzed brass finish. Explore all the finishes pag. 248

Stilla Hexagonal Mirror
890/SE
Bronzed brass details,
uph. Galea Nero C4F.



Il Friuli quassù²
è un tenero verde tra le canne
del mio silenzio

...

Il Friuli prassano^s

2

è un tenero verde tra le canne
del mio silenzio

...

morbidi prati

2

è un tenero verde tra le canne
del mio silenzio

2

Il Friuli quassù
è un tenero verde tra le canne
del mio silenzio

[...]

nell'umido
di morbidi prati

[...]

2

...

Il Friuli quassù²
è un tenero verde tra le canne
del mio silenzio
[...]

nell'umido
di morbidi prati
[...]

s

morbidi prati

Il Friuli quassù²
è un tenero verde tra le canne
del mio silenzio
[...]

nell'umido
di morbidi prati
[...]

Tressa. 175

Poltrona Lounge. Lounge Armchair.

Side by Side. 181

Tavolo Rettangolare. Rectangular Table.

Tavolo Circolare. Circular Table.

Tavolino Circolare. Circular Coffee Table.

Tavolino Ellittico. Elliptical Coffee Table.

Solar. 193

Sedia Dining. Dining Chair.

Poltroncina Dining. Dining Armchair.

Jade. 203

Sofa. Moduli. Modules.

Tressa.

By Chiara Andreatti

Poltrona Lounge. Lounge Armchair.

Firmata da Chiara Andreatti, la poltrona lounge da outdoor Tressa traduce la seduta da esterno in un gesto progettuale avvolgente. La struttura, i braccioli e lo schienale sono realizzati in legno massello di iroko, materiale scelto per la sua naturale resistenza agli agenti atmosferici e per la profondità materica che conferisce al disegno. Le proporzioni generose definiscono una presenza equilibrata nello spazio: braccioli e schienale tracciano un perimetro continuo che accoglie gli ampi cuscini di seduta e schienale, creando un dialogo tra architettura e imbottito.

Designed by Chiara Andreatti, the Tressa outdoor lounge chair reinterprets outdoor seating as an enveloping design gesture. The structure, armrests, and backrest are crafted from solid iroko, a material chosen for its natural resistance to the elements and for the depth and warmth it brings to the design. Generous proportions define a balanced presence within the space: the armrests and backrest trace a continuous perimeter that embraces the ample seat and back cushions, creating a dialogue between structure and upholstery, between architecture and softness.

Tressa. Poltrona Lounge.
Lounge Armchair.



Tressa Lounge Armchair
587/PL
Iroko wood frame,
uph. Shore Terracotta F1A.

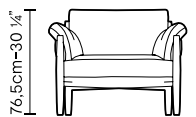
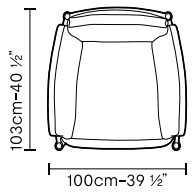

Tressa. Finiture Finishes.

Collezione composta da poltrona lounge con struttura, braccioli e schienale in massello di Iroko con seduta e schienale imbottiti e sfoderabili disponibili nei rivestimenti outdoor a collezione. Esplora tutte le finiture pag. 248

Collection composed of a lounge armchair with structure, armrests, and backrest in solid Iroko wood, featuring an upholstered seat and backrest with removable covers, available in the outdoor upholstery options of the collection. Explore all the finishes pag. 248

Tressa Lounge Armchair
587/PL
Iroko wood frame,
uph. Shore Terracotta F1A.



Side by Side. By Potocco D&D

Tavolo Rettangolare. Rectangular Table.
Tavolo Circolare. Circular Table.
Tavolino Circolare. Circular Coffee Table.
Tavolino Ellittico. Elliptical Coffee Table.

Side by Side è una collezione di tavoli e tavolini disegnata dal team D&D di Potocco. Il progetto si fonda su un basamento sfaccettato, rivestito da listelli in vetro che, attraverso variazioni cromatiche e compositive, generano superfici vibranti e cangianti alla luce. I coffee table sono disponibili con piano circolare o ellittico mentre i tavoli da pranzo propongono piani rettangolari o circolari con proporzioni calibrate e leggerezza visiva.

Side by Side is a collection of tables and coffee tables designed by Potocco's D&D team. The project is centered on a faceted base clad in glass slats that, through chromatic and compositional variations, create vibrant surfaces that shimmer and shift in the light. The coffee tables are available with circular or elliptical tops, while the dining tables feature rectangular or circular tops, defined by calibrated proportions and visual lightness.

Side by Side. Tavolo Rettangolare.
Rectangular Table.



Side by Side Rectangular Table
703/TR-OUT
Amarena lacquered metal base plate,
Amarena, Orchidea and Porpora back-painted glass slats base,
Amarena back-painted glass top.

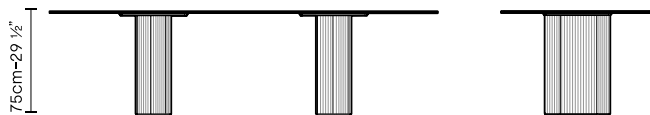
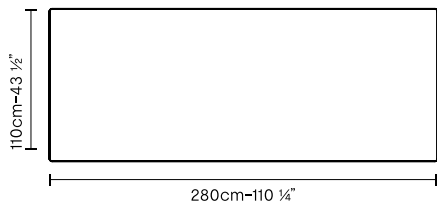



Side by Side Rectangular Table
703/TR-OUT
Amarena lacquered metal base plate,
Amarena, Orchidea and Porpora
back-painted glass slats base,
Amarena back-painted glass top.

Side by Side. Tavolo Circolare.
Circular Table.



Side by Side Circular Table
703/TC-OUT
Menta lacquered metal base plate,
Cielo, Menta and Salvia back-painted glass slats base,
Menta back-painted glass top.

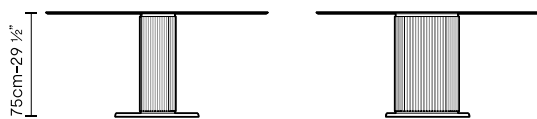
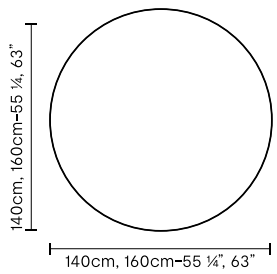

Side by Side. Tavolino Circolare.
Circular Coffee Table.

Tavolino Ellittico.
Elliptical Coffee Table.



Tavolino Circolare. Circular Coffee Table
703/TBC-OUT

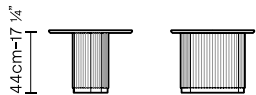
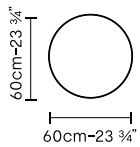

Tavolino Ellittico. Elliptical Coffee Table
703/TBE-OUT

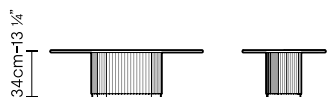
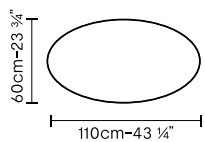

Side by Side Circular Coffee Table
703/TBC-OUT

Menta lacquered metal base plate,
Menta back-painted glass slats base,
Menta back-painted glass top.

Side by Side Elliptical Coffee Table
703/TBE-OUT

Amarena lacquered metal base plate,
Amarena back-painted glass slats base,
Amarena back-painted glass top.

Side by Side. Finiture. Finishes.

Collezione di tavoli e tavolini in diverse forme e altezze con struttura rivestita da listelli di vetro tinta unita o multicolore e piano disponibile in vetro. Esplora tutte le finiture pag. 250

Collection of tables and coffee tables available in various shapes and heights, featuring a structure clad in solid-color or multicolored glass slats and a glass top. Explore all the finishes pag. 250

Side by Side Circular Table
703/TC-OUT
Menta lacquered metal base plate,
Cielo, Menta and Salvia back-painted glass slats base,
Menta back-painted glass top.



Solar. By Mario Ferrarini

Sedia Dining. Dining Chair.
Poltroncina Dining. Dining Armchair.

La collezione Solar, disegnata da Mario Ferrarini, si amplia con una nuova versione di sedia e poltroncina, coniugando il proprio linguaggio in chiave essenziale. La sedia e la poltroncina si declinano in diverse configurazioni, giocando con l'alternanza tra teak e imbottiture per creare atmosfere sempre nuove. Entrambe le sedute condividono proporzioni pure, bilanciamento volumetrico e coerente dialogo materico: il teak, materia viva e sensibile al tempo, entra in relazione con luce e ambiente, mentre l'imbottitura introduce una dimensione raccolta e tattile.

The Solar collection, designed by Mario Ferrarini, expands with new chair and armchair versions, distilling its language into a more essential expression. Both pieces are offered in a variety of configurations, playing with the alternation of teak and upholstery to create ever-changing atmospheres. They share pure proportions, balanced volumes, and a coherent dialogue of materials: teak, a living material shaped by time, engages with light and its surroundings, while the upholstered elements introduce a tactile and intimate dimension.

Solar. Sedia Dining.
Dining Chair.



Solar Dining Chair
961
Anthracite powder-coated aluminum frame,
uph. Seal Beige A1P.

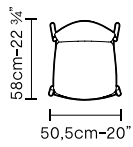

Solar. Sedia Dining.
Dining Chair.



Solar Dining Chair
961/W
Anthracite powder-coated aluminum frame,
teak wood seat and backrest,
uph. Seal Beige A1P.

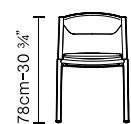
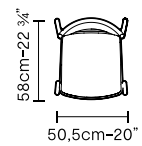

Solar. Poltroncina Dining.
Dining Armchair.



Solar Dining Armchair

961/PW

Anthracite powder-coated aluminum frame,
teak wood armrests and backrest,
uph. Seal Beige AIP.

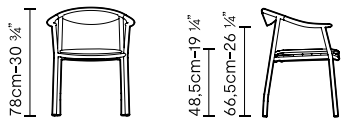
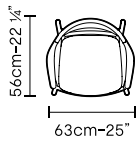

Solar. Finiture. Finishes.

Collezione composta da sedute e poltroncine dining con struttura in alluminio disponibile con seduta e schienale imbottiti nei rivestimenti a collezione e con seduta e schienale in teak con l'opzione di aggiunta di cuscino imbottito e sfoderabile disponibile nei rivestimenti outdoor a collezione; braccioli della poltroncina disponibili in teak. Esplora tutte le finiture pag. 248

Collection composed of dining seats and dining armchairs with an aluminum frame, available with upholstered seat and backrest in the upholstery options of the collection, or with teak seat and backrest, with the option to add an upholstered and removable cushion available in the outdoor upholstery options of the collection; armrests of the dining armchair available in teak. Explore all the finishes pag. 248

Solar Dining Armchair
961/PW
Anthracite powder-coated aluminum frame,
teak wood armrests and backrest,
uph. Seal Beige AIP.



Jade.

By Hanne Willmann

Chaise Longue.
Sofa. 2 Posti. 2 Seater.
Sofa. Moduli. Modules.

La collezione Jade viene proposta per gli spazi outdoor con la variante del divano modulare, preservando l'identità sinuosa e organica della famiglia di sedute firmata da Hanne Willmann. Il divano componibile è studiato per resistere agli agenti atmosferici, assicurando relax e praticità all'aria aperta. A livello formale e compositivo, Jade trae ispirazione dalle pietre modellate dall'acqua nei letti dei fiumi, trasformando il divano in un invito a rallentare il ritmo e a gustare pienamente il momento presente.

The Jade collection is extended to outdoor spaces with a modular sofa, preserving the sinuous and organic identity of the seating family designed by Hanne Willmann. The modular system is engineered to withstand outdoor conditions, ensuring comfort and practicality in open-air settings. From a formal and compositional perspective, Jade draws inspiration from stones shaped by flowing water along riverbeds, transforming the sofa into an invitation to slow down and fully embrace the present moment.

Jade. Chaise Longue.



Jade left off-shape chaise
longue unit
953/OCL-SX-OUT
uph. Selva Beige E9B.

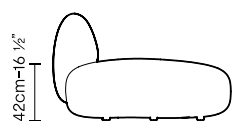
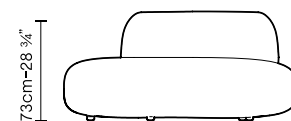
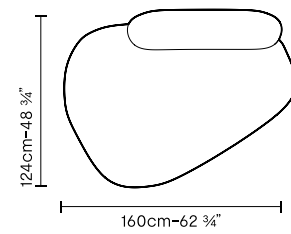

Jade. Sofa. 2 Posti.
2 Seater.



Jade 2 Seater Sofa
953/DT-DX-OUT, 953/DT-SX-OUT,
uph. Selva Beige E9B.

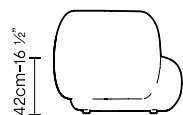
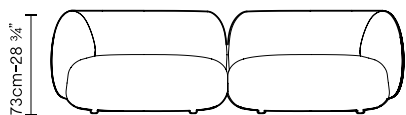
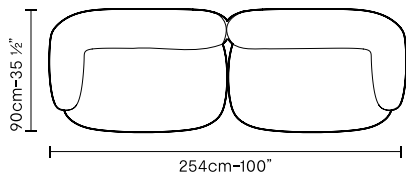



Jade 2 Seater Sofa
953/DT-DX-OUT, 953/DT-SX-OUT,
uph. Selva Beige E9B.

Jade. Sofa. Moduli. Modules.

Modulo Recamiere Destro. Right Recamiere Unit
953/RE-DX-OUT

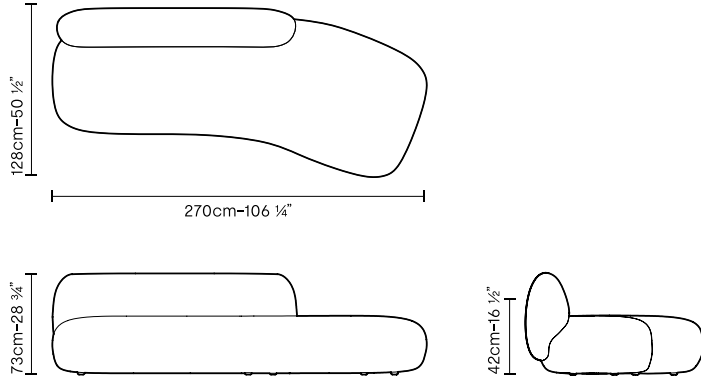

Modulo Off-Shape Corner Sinistro. Left Off-Shape Corner Unit
953/OC-SX-OUT

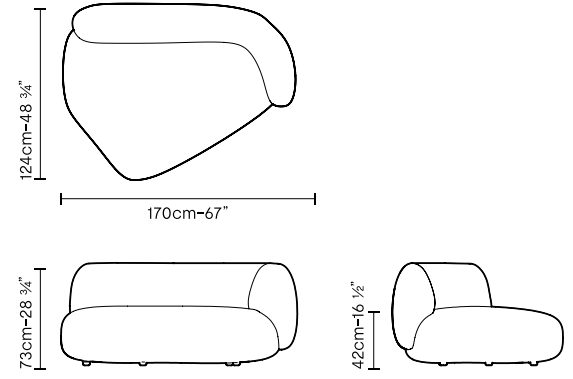

Modulo Recamiere Sinistro. Left Recamiere Unit
953/RE-SX-OUT

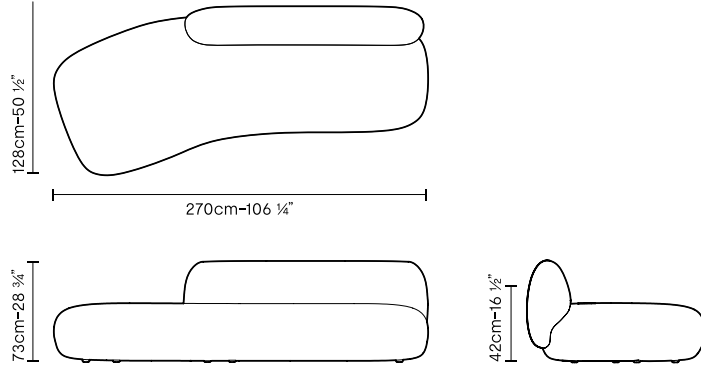

Modulo Combi Corner Destro. Right Combi Corner Unit
953/CC-DX-OUT

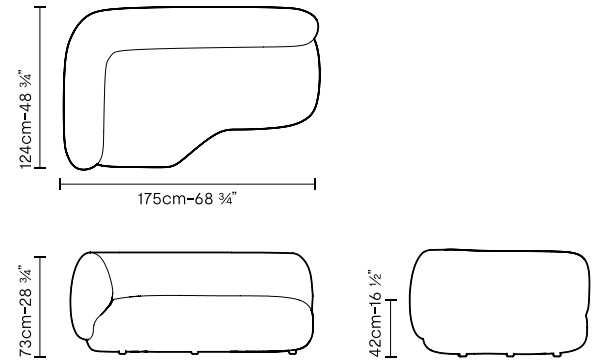

Modulo Off-Shape Corner Destro. Right Off-Shape Corner Unit
953/OC-DX-OUT

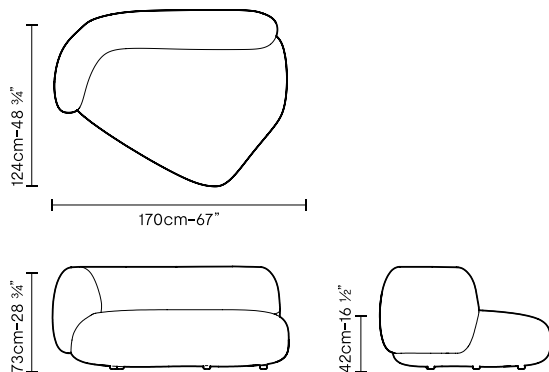

Modulo Combi Corner Sinistro. Left Combi Corner Unit
953/CC-SX-OUT

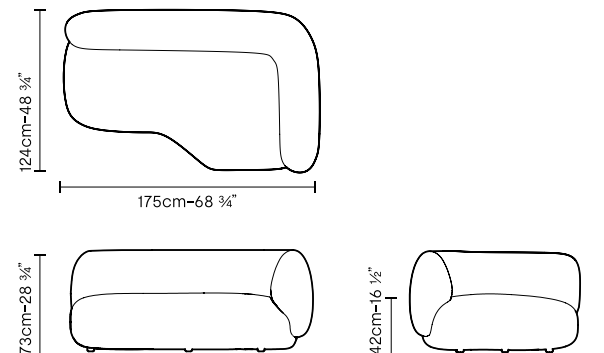

Jade. Sofa. Moduli. Modules.

Modulo Intermedio. Cental Unit
629/DM-OUT

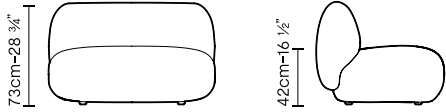
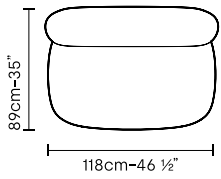

Modulo Intermedio Large. Large Central Unit
953/DML-OUT

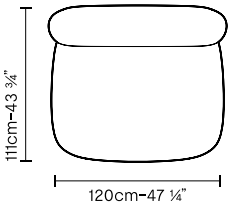

Modulo Corner Destro. Right Corner Unit
953/DT-DX-OUT

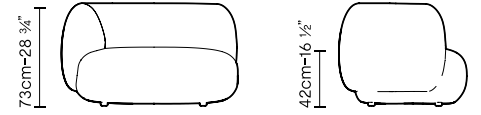
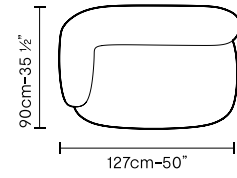

Modulo Corner Sinistro. Left Corner Unit
953/DT-SX-OUT

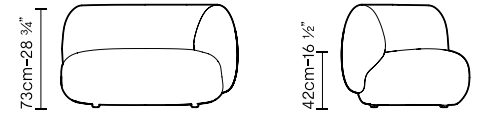
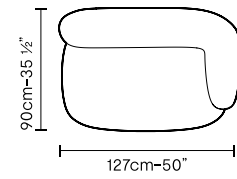

Jade. Sofa. Moduli. Modules.

Modulo Off-Shape Chaise Longue Destro. Right Off-Shape Chaise Longue Unit
953/OCL-DX-OUT

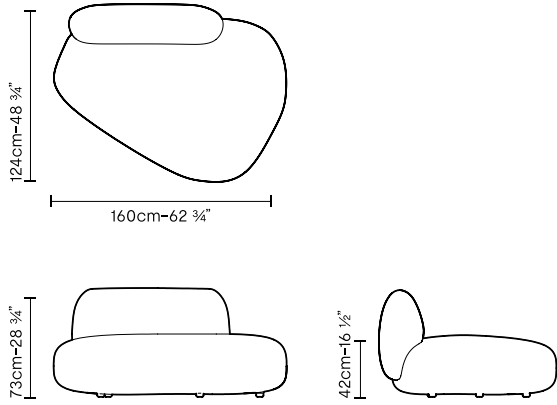

Modulo Off-Shape Chaise Longue Sinistro. Left Off-Shape Chaise Longue Unit
953/OCL-SX-OUT

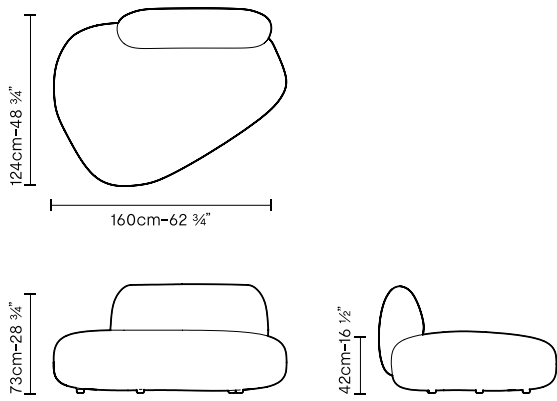

Modulo Off-Shape Pouf. Off-Shape Pouf Unit
953/OL

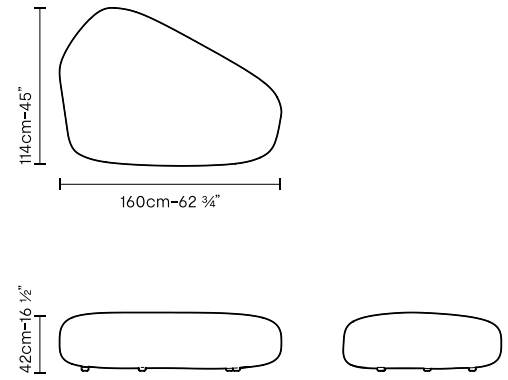

Modulo Off-Shape Pouf Small. Off-Shape Pouf Small Unit
953/O

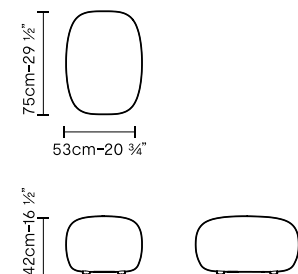

Jade. Finiture. Finishes.

Collezione composta da divano componibile imbottito disponibile nei rivestimenti elastici outdoor a collezione. Esplora tutte le finiture pag. 250

Collection composed of an upholstered modular sofa, available in the outdoor elastic upholstery options of the collection. Explore all the finishes pag. 250

Allora ho cominciato a pensare³
a sentire a sognare
oggetti in piena luce

3 Allora ho cominciato a pensare

a sentire a sognare
oggetti in piena luce

Uomini e donne

3

a sentire a sognare

oggetti in piena luce

Uomini e donne

oggetti in piena luce

Uomini e donne

Uomini e donne

Allora ho cominciato a pensare³
a sentire a sognare
oggetti in piena luce

Uomini e donne
Alberi e terra
[...]

Designers

Architect & Friends.	230
Chiara Andreatti.	232
Favaretto&Partners.	234
Hanne Willmann.	236
Mario Ferrarini.	238
Potocco D&D	240
Serena Confalonieri.	242
Studio Omi Tahara.	244
Vladislav Tolochko.	246

Architect & Friends

Architect & Friends è uno studio di progettazione con base a Grado, in Italia, fondato nel 2008 dall'architetto Michael Atzenhofer e dall'interior designer Johanna Atzenhofer. Dopo essersi conosciuti a Vienna, nel 2004 i due fondatori si trasferiscono in Italia, dove approfondiscono il loro interesse per l'artigianato locale, la cultura dei materiali e il legame tra progetto e contesto. Nel solco di questa sensibilità per la cura dei dettagli e per un design radicato nei luoghi, quest'anno prende avvio la collaborazione con Potocco, nata in modo naturale da uno speciale progetto custom sviluppato insieme e che ha subito rivelato una forte affinità nella visione creativa e nella ricerca di soluzioni su misura.

Architect & Friends is a design studio based in Grado, Italy, founded in 2008 by architect Michael Atzenhofer and interior designer Johanna Atzenhofer. After meeting in Vienna, the two founders moved to Italy in 2004, where they deepened their interest in local craftsmanship, material culture, and the relationship between design and context. Rooted in this sensitivity to detail and to a design approach closely connected to place, their collaboration with Potocco began this year. It developed naturally from a special custom project created together, immediately revealing a strong affinity in creative vision and a shared pursuit of tailor-made solutions.



Products
Eline.

093

Chiara Andreatti

Chiara Andreatti è una designer italiana, formatasi a Milano presso l'Istituto Europeo di Design e la Domus Academy. Dopo diverse collaborazioni con studi di design e architettura, avvia la propria attività come designer indipendente. Dal 2018 collabora con Potocco, firmando numerose collezioni indoor e outdoor. La sua ricerca progettuale affonda le radici nelle origini veneziane, esplorando la cultura artigianale locale e fondendola con una visione poetica, elegante e calda.

Chiara Andreatti is an Italian designer, educated in Milan at the Istituto Europeo di Design and Domus Academy. After collaborating with several design and architecture studios, she established her own practice as an independent designer. Since 2018, she has been working with Potocco, designing numerous indoor and outdoor collections. Her design research is deeply rooted in her Venetian origins, exploring local artisanal culture and blending it with a poetic, elegant, and warm vision.



Products

Orlea.	099
Kira.	111
Tressa.	175

Favaretto&Partners

Francesco Favaretto è un designer italiano laureato in Disegno Industriale allo IUAV di Venezia. Fin dagli studi si confronta con diversi ambiti del progetto, dal product e interior design alla corporate identity e al fashion design. La sua storia professionale è profondamente legata a quella dello studio Favaretto&Partners, fondato negli anni '70 dal padre Paolo Favaretto, con il quale prende avvio anche la collaborazione con Potocco. Dal 2009 Francesco collabora stabilmente nello studio, di cui è oggi Direttore Creativo, e negli ultimi anni ha ripreso e proseguito questo dialogo con Potocco, rinnovando la collaborazione di lunga data e portandola verso nuove interpretazioni contemporanee.

Francesco Favaretto is an Italian designer who graduated in Industrial Design from IUAV University of Venice. Since his studies, he has explored different design fields, ranging from product and interior design to corporate identity and fashion design. His professional path is closely linked to Favaretto&Partners, the studio founded in the 1970s by his father Paolo Favaretto, which also marks the beginning of the collaboration with Potocco. Since 2009, Francesco has been a permanent member of the studio, where he now serves as Creative Director. In recent years, he has renewed and continued this long-standing dialogue with Potocco, reinterpreting the collaboration through new contemporary perspectives.



Products

Petalus.	025
Stadium.	043
Stadium Cane.	053

Hanne Willmann

Hanne Willmann è una designer tedesca, fondatrice dello Studio Hanne Willmann con sede a Berlino. Dopo un'esperienza in due studi internazionali, nel 2015 avvia la propria attività. Il suo lavoro si concentra su industrial e product design e consulenza creativa, con una particolare attenzione alla qualità dei materiali, alla precisione del dettaglio e all'equilibrio tra funzione ed estetica. È proprio questa visione, che unisce comfort ed eleganza, ad aver dato origine già da alcuni anni alla collaborazione con Potocco, una partnership costruita sulla condivisione di un approccio al design capace di creare arredi accoglienti, raffinati e pensati per l'uso quotidiano.

Hanne Willmann is a German designer and founder of Studio Hanne Willmann, based in Berlin. After gaining experience at two international design studios, she established her own practice in 2015. Her work focuses on industrial and product design as well as creative consultancy, with particular attention to material quality, precision in detailing, and the balance between function and aesthetics. It is precisely this vision—combining comfort and elegance—that gave rise, several years ago, to her collaboration with Potocco: a partnership built on a shared design approach aimed at creating welcoming, refined furniture conceived for everyday use.



Products

Jade. Bed	133
Jade. Modular sofa	203

Mario Ferrarini

Mario Ferrarini è un designer italiano formatosi a Milano, dove si laurea in Industrial Design al Politecnico. Dal 2004 avvia collaborazioni con importanti studi di design e architettura, occupandosi di sviluppo prodotto e interior design. Nel 2007 fonda il proprio studio, prima a Como e successivamente a Lugano, in Svizzera, sviluppando soluzioni che coniugano ricerca formale, attenzione ai materiali e innovazione progettuale. Da oltre dieci anni collabora con Potocco, un percorso condiviso che ha dato vita a collezioni capaci di esprimere la sua visione progettuale e che, nel tempo, sono diventate veri e propri best seller della nostra produzione.

Mario Ferrarini is an Italian designer educated in Milan, where he graduated in Industrial Design from the Politecnico di Milano. Since 2004, he has collaborated with leading design and architecture studios, working in product development and interior design. In 2007, he founded his own studio, first in Como and later in Lugano, Switzerland, developing solutions that combine formal research, careful attention to materials, and design innovation. For over ten years, he has been collaborating with Potocco, a shared journey that has resulted in collections capable of expressing his design vision and that, over time, have become true best sellers of our production.



Products

Velvet.	065
Velis.	149
Solar.	193

Potocco D&D

Il gruppo Design & Development è il cuore creativo dell'azienda: un team interdisciplinare guidato da Alice Potocco che unisce visione estetica e competenze tecniche per trasformare idee in prodotti concreti. Lavora tra forma, funzione e innovazione, seguendo ogni fase del progetto. Attraverso ricerca sui materiali, sperimentazione e collaborazione con tutti i reparti aziendali, il team garantisce coerenza, qualità e fattibilità. È il motore che traduce insight e opportunità in soluzioni di design capaci di rafforzare l'identità del brand e migliorare l'esperienza dell'utente.

The Design & Development team is the creative core of the company: an interdisciplinary group led by Alice Potocco that combines aesthetic vision with technical expertise to transform ideas into tangible products. Working across form, function, and innovation, the team oversees every stage of the design process. Through material research, experimentation, and close collaboration with all company departments, it ensures coherence, quality, and feasibility. It is the driving force that translates insights and opportunities into design solutions capable of strengthening brand identity and enhancing the user experience.



Products

Side by Side.	121
Side by Side. Outdoor	181

Serena Confalonieri

Serena Confalonieri è una designer italiana indipendente e art director che vive e lavora a Milano. È specializzata in product, graphic e textile design. I suoi lavori si collocano spesso a metà strada tra prodotto e grafica, con una particolare attenzione alla ricerca sui materiali e ai linguaggi visivi. La collaborazione con Potocco, attiva da alcuni anni, nasce proprio da questa sua capacità di coniugare segno e materia ed è stata lei la prima designer a introdurre nel nostro catalogo una collezione di specchi, aprendo nuove prospettive espressive all'interno dell'azienda.

Serena Confalonieri is an independent Italian designer and art director who lives and works in Milan. She specializes in product, graphic, and textile design. Her work often sits at the intersection of product and graphics, with a strong focus on material research and visual language. Her collaboration with Potocco, ongoing for several years, stems precisely from this ability to combine sign and matter. She was the first designer to introduce a mirror collection into our catalogue, opening up new expressive perspectives within the company.



Products
Stilla.

155

Studio Omi Tahara

Studio Omi Tahara è uno studio di design e consulenza con sede a Milano, fondato nel 2011 dal designer giapponese Omi Tahara. Dopo la laurea in ingegneria civile in Giappone, Omi Tahara sviluppa un forte interesse per il design contemporaneo che nel 2003 lo porta a trasferirsi a Milano, dove collabora con diversi designer, approfondendo la cultura del design italiano. Il suo lavoro si distingue per un linguaggio essenziale e per una particolare attenzione al dettaglio e alla qualità dei materiali, un approccio che dal 2025 condividiamo attraverso la collaborazione con Potocco, nata in continuità con questa sensibilità per forme pure e materiali ricercati.

Studio Omi Tahara is a design and consultancy studio based in Milan, founded in 2011 by Japanese designer Omi Tahara. After graduating in Civil Engineering in Japan, Omi Tahara developed a strong interest in contemporary design, which led him to move to Milan in 2003. There, he collaborated with various designers, deepening his understanding of Italian design culture. His work is distinguished by an essential design language and a strong focus on detail and material quality—an approach that, since 2025, has been shared through the collaboration with Potocco, born from a common sensitivity to pure forms and refined materials.



Products
Canyons.

073

Vladislav Tolochko

Vladislav Tolochko è un designer e architetto che ha fondato il proprio studio nel 2020. Il suo lavoro si concentra sull'equilibrio tra forma, proporzione e percezione, con un'attenzione particolare alla relazione tra oggetti e ambiente. Focalizzato sul design di interni, sul product design, sui progetti di architettura e sulla direzione artistica, i suoi progetti mirano a influenzare positivamente il modo in cui le persone vivono e percepiscono lo spazio che le circonda. Nel 2025 prende avvio la collaborazione con Potocco, nata in continuità con questa sua ricerca sull'armonia tra oggetto e spazio.

Vladislav Tolochko is a designer and architect who founded his own studio in 2020. His work focuses on the balance between form, proportion, and perception, with particular attention to the relationship between objects and their surrounding environment. Centered on interior design, product design, architectural projects, and art direction, his practice aims to positively influence the way people live in and perceive the spaces around them. In 2025, his collaboration with Potocco began, naturally aligned with his ongoing research into the harmony between object and space.



Products
Softy.

141

Frassino. Ash Wood.
Frassino Tinto Colori Speciali.
Ash Wood Stained Special Colors.
Essenze Speciali. Special Essences.
Canna Naturale. Natural Cane.
Metalli Verniciati. Lacquered Metals.
Metalli Speciali. Special Metals.
Metalli Cromati. Chrome Metals.
Marmi. Marbles.
Listelli Di Vetro. Glass Slats.
Vetro Retro-Verniciato. Back-Painted Glass.

Coverings. Indoor.**261**

Aida.
Arte.
Baldo.
Betty.
Bess.
Bliss.
Bridge.
Calla.
Cielo.
Cortina.
Cross.
Dalí.
Delta.
Dedalo.
Dolly.
Duna.
Flamingo B.
Feya.
Geo.
Galea.
Nabuk.
Cuoietto.

Coverings. Outdoor.**277**

Shore.
Seal.
Samos.
Santorini.
Symi.
Selva.
Soul.
Summer.
Sunset.

Materials.

Frassino. Ash Wood.

Frassino Tinto Colori Speciali.

Ash Wood Stained Special Colors.

Essenze Speciali. Special Essences.

Canna Naturale. Natural Cane.

Metalli Verniciati. Lacquered Metals.

Metalli Speciali. Special Metals.

Metalli Cromati. Chrome Metals.

Marmi. Marbles.

Listelli Di Vetro. Glass Slats.

Vetro Retro-Verniciato. Back-Painted Glass.

Frassino
Ash Wood



HG. Naturale puro | Pure natural



SG. Beige



SC. Biscotto | Biscuit



HJ. Moka



HK. Grigio plumbeo | Dark grey



HL. Wengé



HP. Carbone | Carbon



SN. Noce | Walnut

Frassino Tinto Colori Speciali
Ash Wood Stained Special Colors



HD. White



HE. Cherry

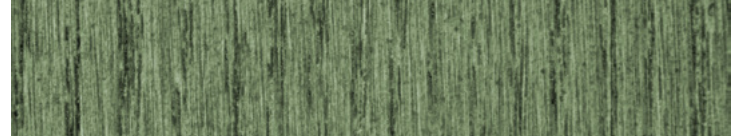

HF. Olive green

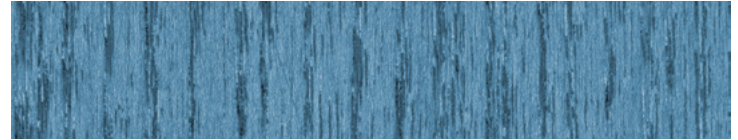

HC. Bluette

Frassino Laccato Lucido
Glossy Lacquered Ash Wood



RAL. 7022

Radica
Burl Wood



ZF. Opaca | Matt

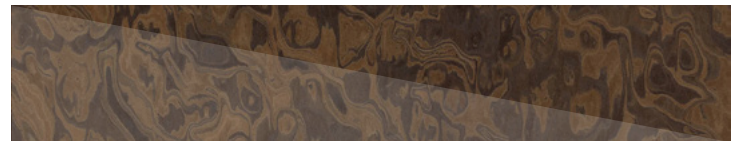

ZT. Lucida | Glossy

Essenze Speciali
Special Essences (Outdoor)



EU. Iroko



Teak

Canna
Cane



Canna naturale | Natural cane

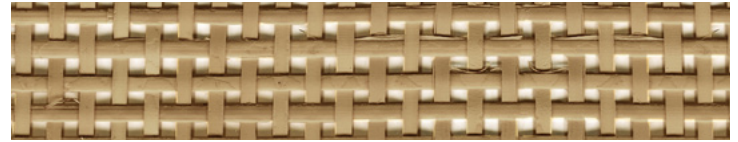

Canna tinta beige | Beige stained cane



Canna tinta biscotto | Biscuit stained cane



Canna tinta moka | Moka stained cane



Canna tinta grigio plumbeo | Dark grey stained cane



Canna tinta wengé | Wengé stained cane



Canna tinta carbone | Carbon stained cane



Canna tinta noce | Walnut stained cane

Marmo
Marble



Bianco Carrara lucido | Glossy White Carrara



Bianco Carrara opaco | Matt White Carrara



Fior Di Pesco Carnico

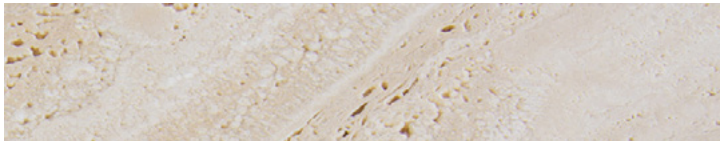

Travertino Romano

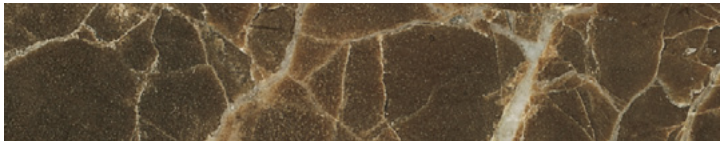

Dark Emperador

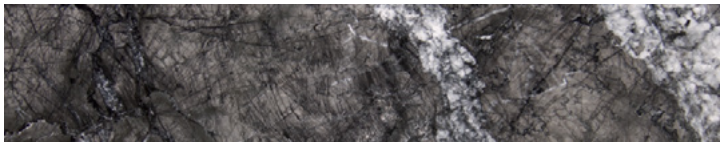

Grigio Carnico



Nero Marquina

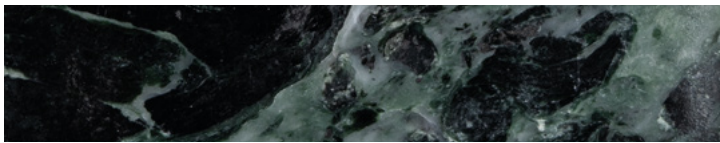

Verde Alpi

Metalli Verniciati
Lacquered Metals



Beige gofrato | Beige embossed

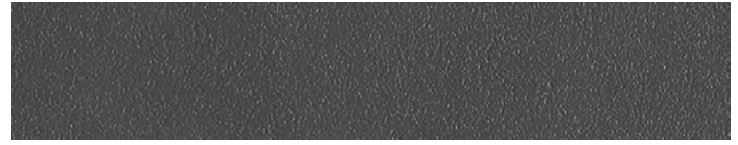

Antracite gofrato | Anthracite embossed

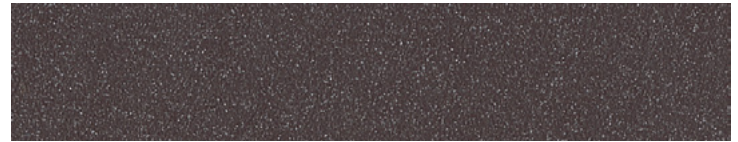

Aval gofrato | Aval embossed

Metalli speciali
Special metals



Ottone brunito | Bronzed brass

Metalli cromati
Chromed metals



Cromato | Chrome



Cromo nero | Black chrome

Listelli Di Vetro
Glass Slats



Orchidea



Amarena



Porpora



Cielo



Menta



Salvia



Liquirizia

Vetro Retro-Verniciato
Back-Painted Glass



Orchidea



Amarena



Porpora



Cielo



Menta



Salvia



Liquirizia

Coverings. Indoor.

Aida.

Arte.

Baldo.

Betty.

Bess.

Bliss.

Bridge.

Calla.

Cielo.

Cortina.

Cross.

Dalí.

Delta.

Dedalo.

Dolly.

Duna.

Flamingo B.

Feya.

Geo.

Galea.

Nabuk.

Cuoietto.

Aida
(Cat. 1)



A2D. Bianco



A2E. Beige

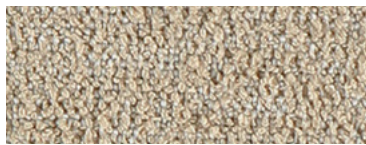

A2F. Sabbia

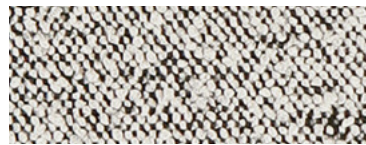

A2G. Pepe

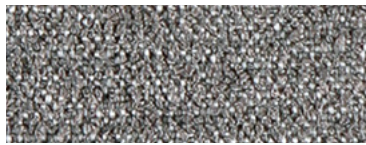

A2H. Grigio



A2J. Tronco



A2I. Antracite



A2K. Rubino

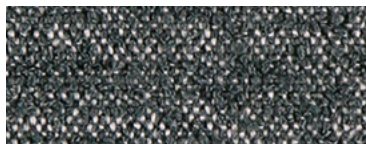

A2L. Petrolio

Arte
(Cat. 1)



A1J. Beige

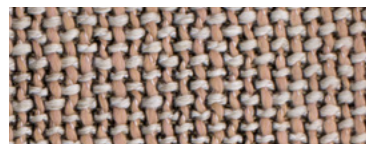

A1E. Rosa



A1T. Tortora

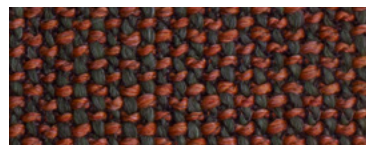

A1G. Verde mattone

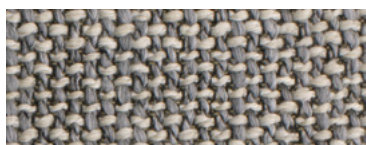

A1F. Grigio chiaro

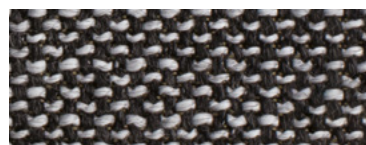

A1H. Pepe

Baldo
(Cat. 2)



B7B. Beige



B7C. Avorio

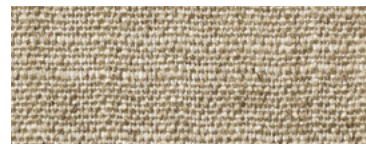

B7D. Tortora



B7F. Rosa



B7G. Grigio chiaro



B7H. Grigio scuro

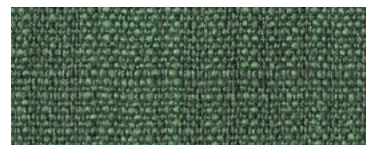

B7J. Bosco



B7K. Nocciola

Betty
(Cat. 2)

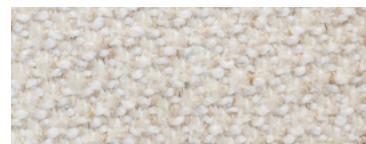

A9K. Bianco

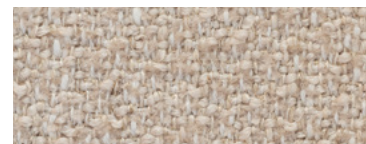

A9L. Beige



A9M. Grigio chiaro



A9N. Nocciola

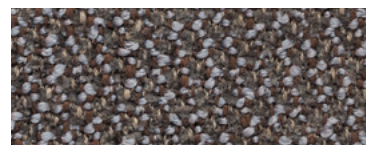

A9P. Antracite

Bess
(Cat. 2)

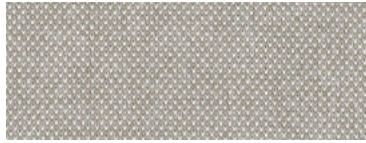

D1G. Beige chiaro

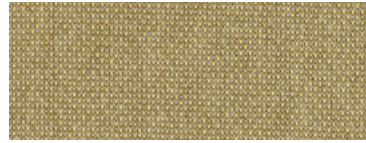

D1H. Lime



D1I. Cammello

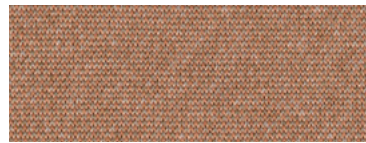

D1U. Rosa

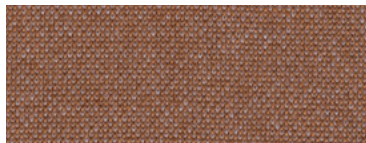

D1J. Terracotta



D1K. Senape

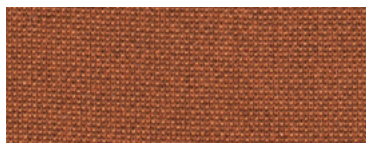

D1L. Mattone



D1M. Bosco



D1N. Salvia



D1P. Lilla

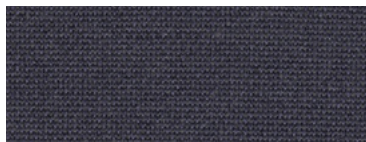

D1Q. Antracite

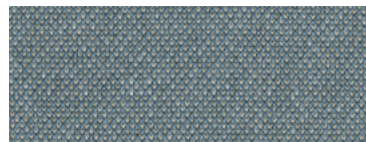

D1R. Celeste

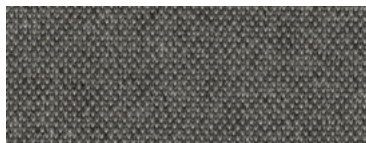

D1S. Fango



D1T. Grigio chiaro

Bliss
(Cat. 2)

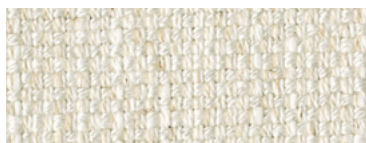

H1X. Bianco

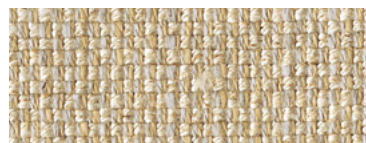

H1Z. Beige



H1Y. Panna

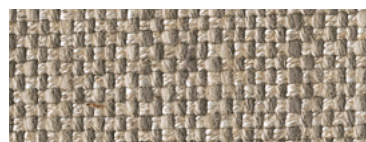

H1W. Nocciola

Bridge
(Cat. 2)



A3D. Bianco



A3R. Nocciola

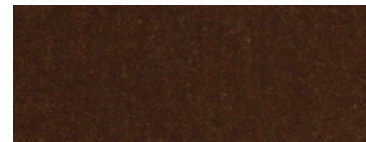

A3Q. Tronco

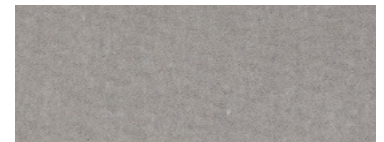

A3F. Grigio

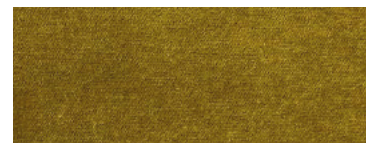

A3P. Oliva

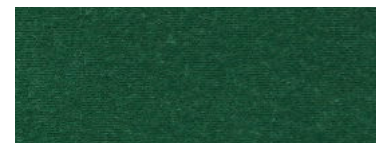

A3N. Bosco



A3H. Salvia



A3I. Mattone

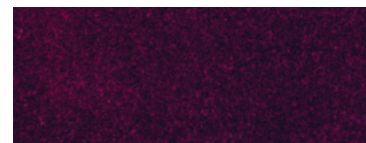

A3J. Prugna



A3M. Bluette

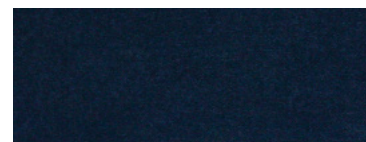

A3K. Blu oltremare

Calla
(Cat. 3)

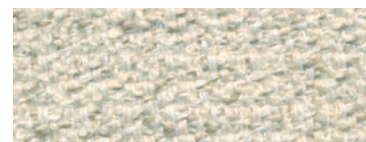

A8L. Panna

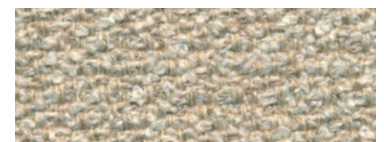

A8M. Sabbia

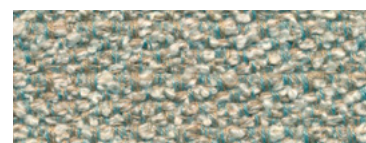

A8N. Smeraldo

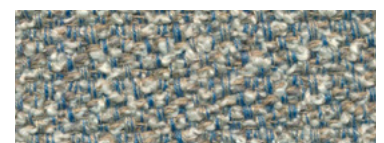

A8P. Celeste



A8Q. Pepe

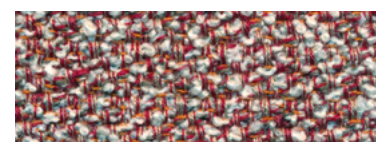

A8R. Rubino

Cielo
(Cat. 3)

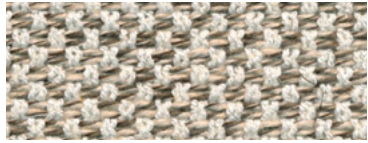

A6H. Panna

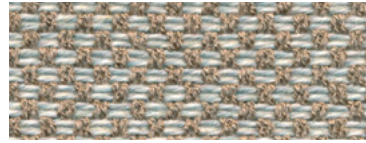

A6K. Sabbia



A6I. Blu oltremare

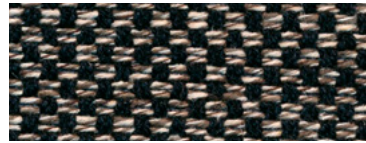

A6J. Tronco



A6L. Mattone

Cross
(Cat. 3)



A2M. Avorio



A2Q. Antracite



A2R. Blue

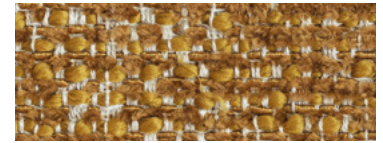

A2S. Ocra



A2T. Salvia

Cortina
(Cat. 3)



A9E. Beige

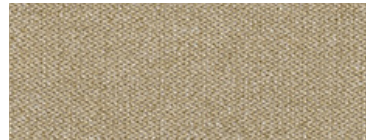

A9R. Sabbia



A9S. Limone

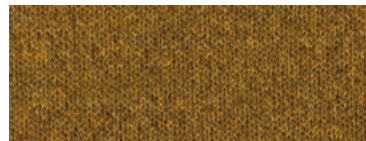

A9H. Senape

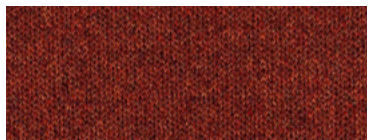

A9J. Mattone

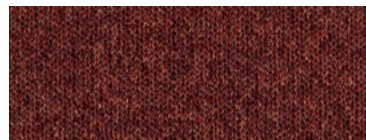

A9I. Terracotta



A9B. Salvia

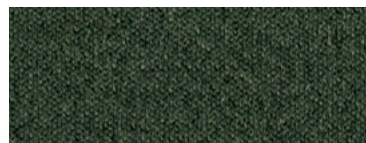

A9A. Bosco



A9D. Avio

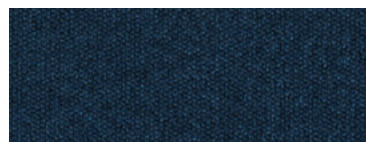

A9C. Blu oltremare



A9F. Grigio

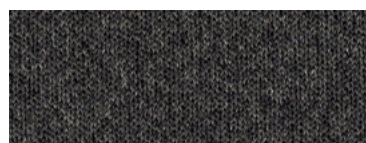

A9G. Antracite

Dalí
(Cat. 4)

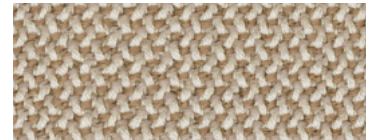

C6V. Sabbia

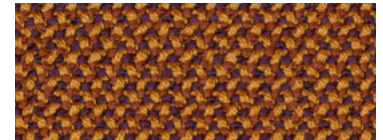

C6H. Senape

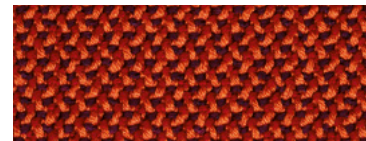

C6T. Arancione



C6N. Salvia

Delta
(Cat. 4)

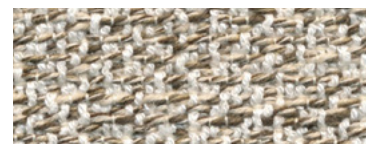

B1C. Panna melange

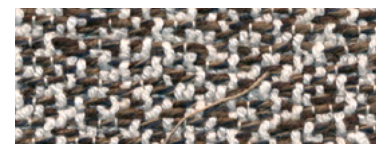

B1D. Tronco melange

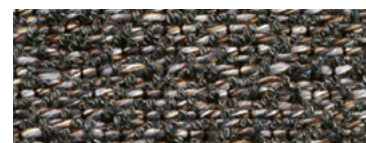

B1E. Antracite melange

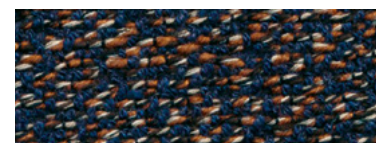

B1F. Blu mattone

Dedalo
(Cat. 4)



E5C. Perla



E5D. Grigio



E5E. Senape

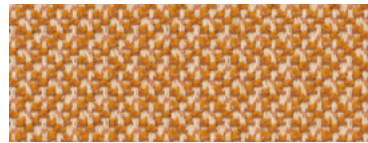

E5B. Terracotta

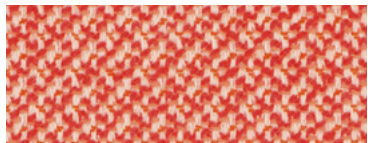

E5F. Fragola

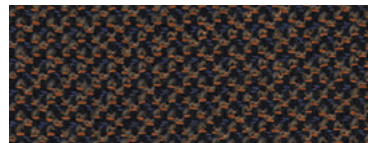

E5H. Castagna



E5G. Lava

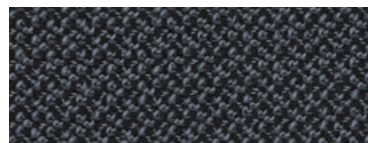

E5A. Blu Antracite

Duna
(Cat. 4)

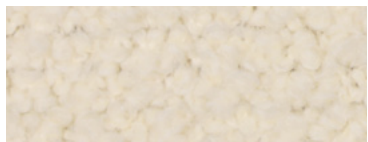

S6B. Panna

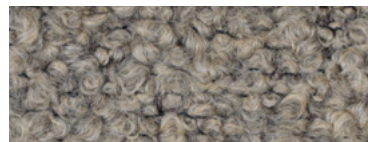

S6C. Tortora

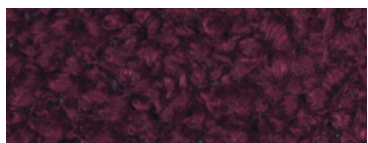

S6D. Bordeaux



S6E. Senape

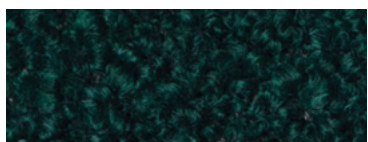

S6F. Pavone

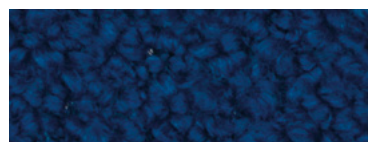

S6G. Bluette

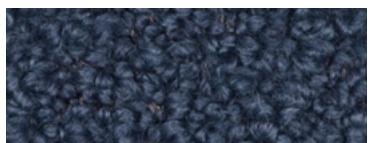

S6A. Pervinca

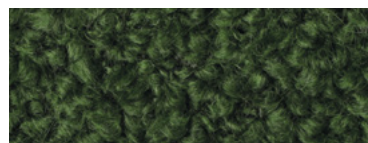

S6H. Bosco

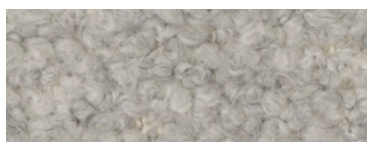

S6I. Grigio

Dolly
(Cat. 4)

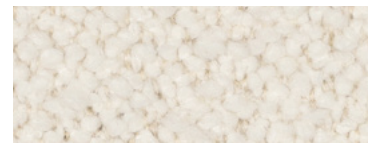

Q2A. Panna

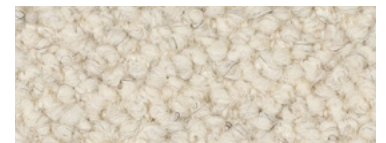

Q2B. Avorio

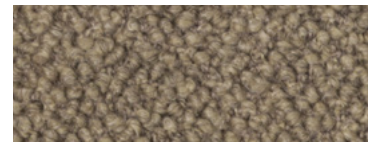

Q2C. Tortora

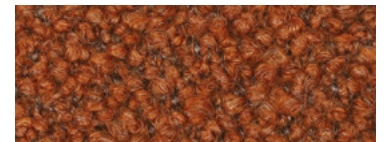

Q2D. Mattone

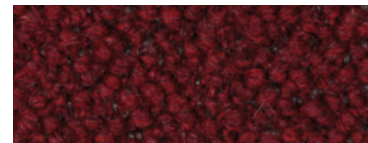

Q2I. Bordeaux

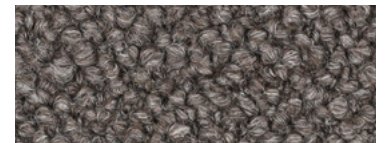

Q2E. Grigio

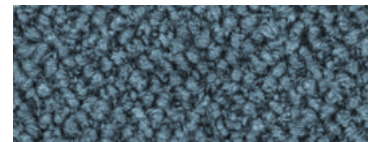

Q2J. Cielo

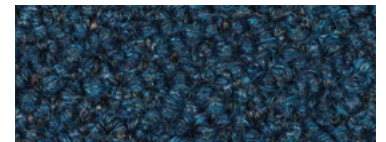

Q2F. Petrolio

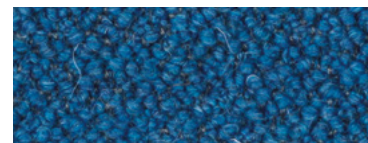

Q2L. Bluette

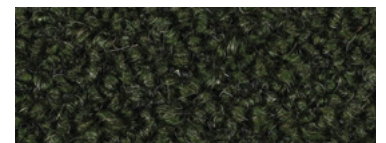

Q2G. Bosco

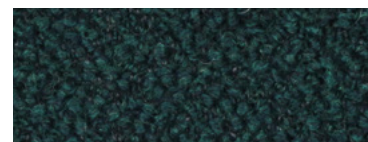

Q2V. Pavone

Finta Pelle Flamingo B
Flamingo B Faux Leather (Cat. 2)



Q1C. Ecrú

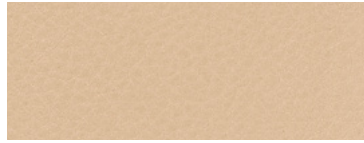

Q1D. Beige

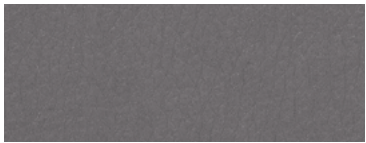

Q1E. Grigio scuro



Q1A. Tortora scuro

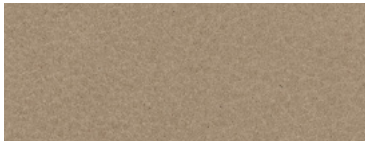

Q1F. Nocciola

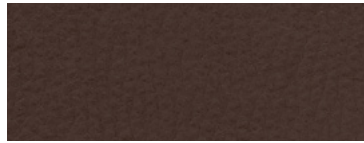

Q1G. Mogano

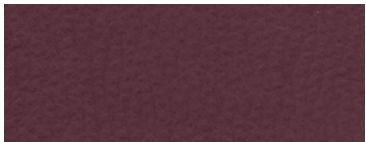

Q1H. Bordeaux

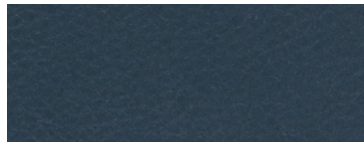

Q1I. Blu notte

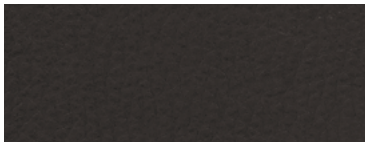

Q1B. Nero

Finta Pelle Feyá
Feyá Faux Leather (Cat. 3)

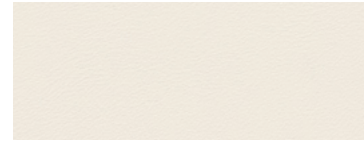

N4A. Panna



N4B. Beige



N4C. Terracotta

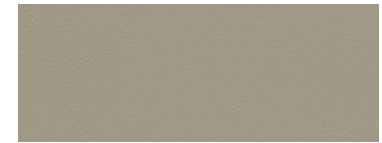

N4D. Ecrú

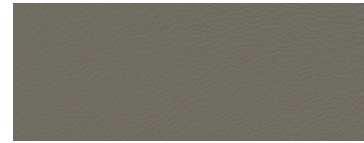

N4E. Tortora



N4F. Tronco

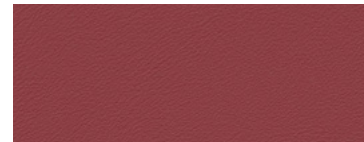

N4G. Bordeaux

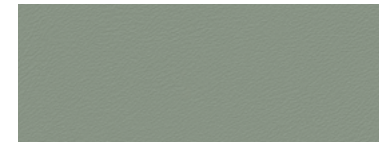

N4H. Salvia



N4I. Cielo

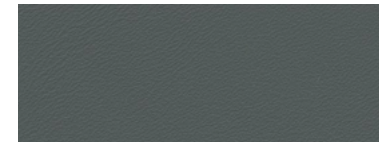

N4J. Antracite

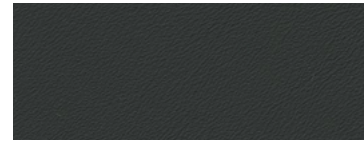

N4K. Nero

Pelle Geo
Geo Leather (Cat. A)

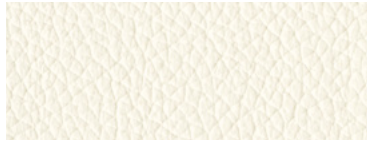

P2A. Panna



P1B. Grano



P1D. Beige scuro



P2D. Tortora



P2C. Ruggine



P1K. Nocciola



P1M. Tronco

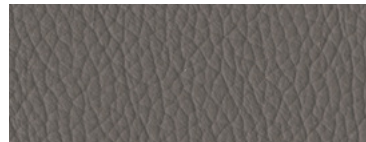

P2G. Grigio scuro



P1N. Noce



P2H. Marrone scuro



P1T. Terracotta



P1V. Rosso



P1W. Bordeaux

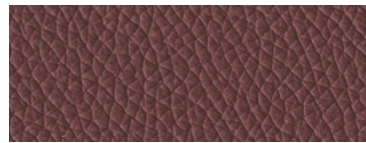

P2N. Melanzana

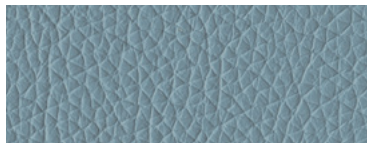

P2Q. Celeste

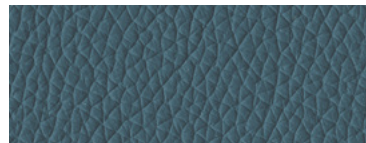

P2S. Blu cadetto

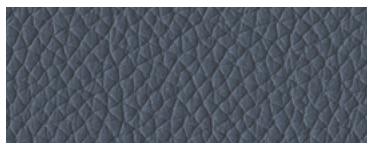

P2T. Blu prussia

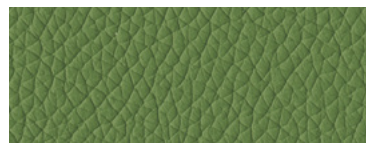

P3B. Verde chiaro

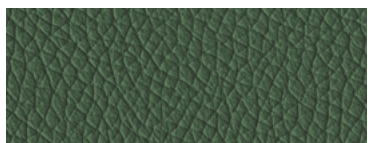

P3C. Verde

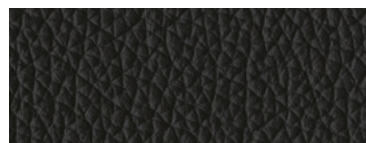

P2F. Nero

Pelle Galea
Galea Leather (Cat. B)

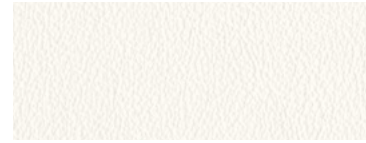

C4I. Bianco



C4Q. Beige



C4T. Tortora chiaro



C4U. Tortora



C4P. Zucca



C4H. Rosso scuro

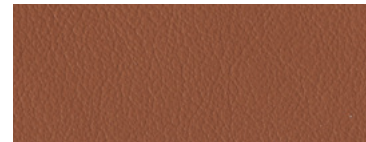

C4V. Dattero

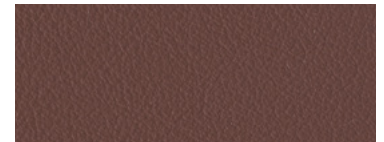

C4K. Castagna

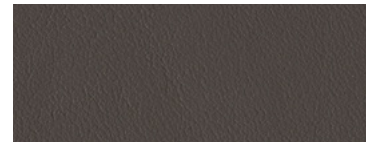

C4L. Marrone scuro



C4S. Marmotta



C4W Verde muschio



C4N Verde mimetico



C4R. Grigio



C4J. Grigio chiaro

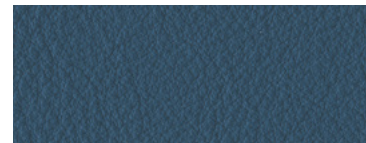

C4G. Bluette

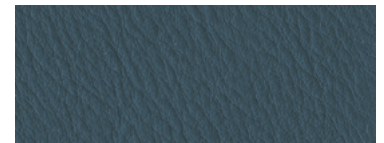

C4M. Blu

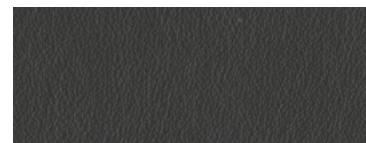

C4F. Nero

Pelle Nabuk
Nabuk Leather (Cat. C)



E2Q. Nocciola



E2T. Tortora



E2R. Avena



E2U. Marmotta

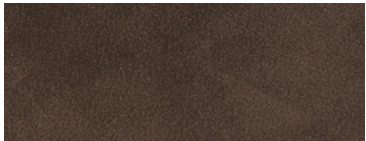

E2S. Wengé



E2V. Blu

Cuoietto
Hide Leather

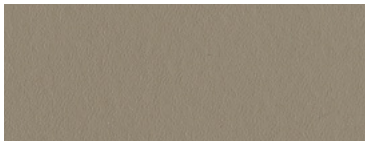

K1B. Fango

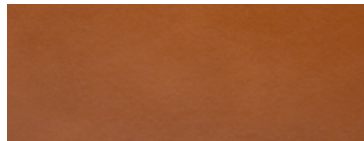

IZ. Cognac

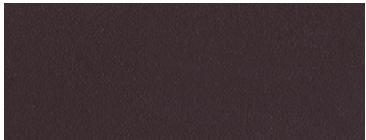

K1D. Marrone scuro

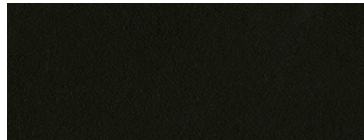

BM. Nero

Coverings. Outdoor.

Shore.

Seal.

Samos.

Santorini.

Symi.

Selva.

Soul.

Summer.

Sunset.

Shore
Outdoor (Cat. 1)

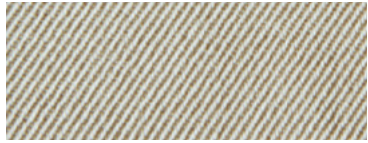

F1C. Beige



F1D. Tortora



F1E. Grigio



F1B. Cammello

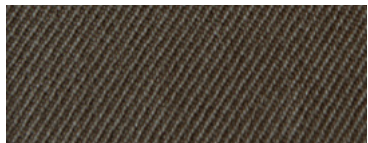

F1F. Nocciola

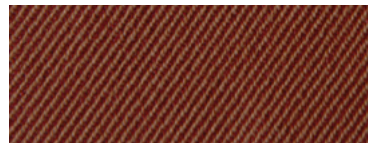

F1A. Terracotta

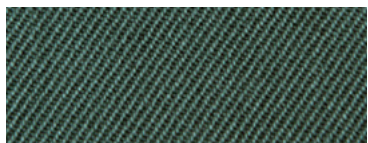

F1H. Pavone

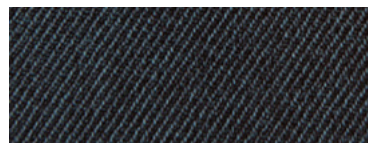

F1G. Blue navy

Seal
Outdoor (Cat. 2)

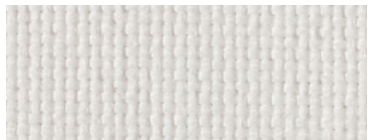

A1M. Bianco



A1N. Bianco melange



A1P. Beige



A1R. Grigio melange



A1U. Nocciola



A1V. Grigio scuro

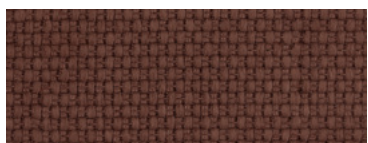

A1W. Bordeaux

Samos
Outdoor (Cat. 3)



N3F. Panna



N3E. Beige



N3B. Grigio

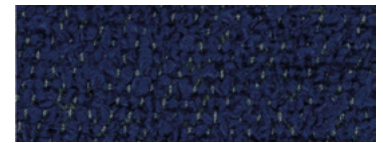

N3A. Blu

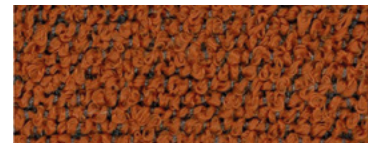

N3C. Mattone

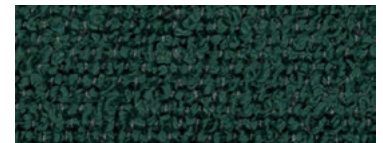

N3D. Bosco

Santorini
Outdoor (Cat. 3)

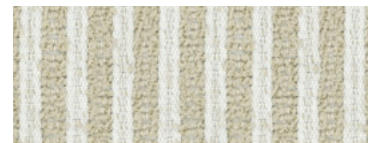

S7E. Beige

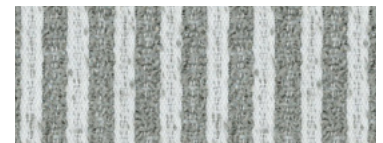

S7A. Grigio

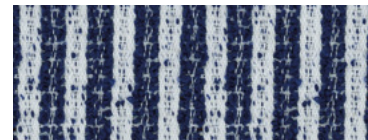

S7B. Blu

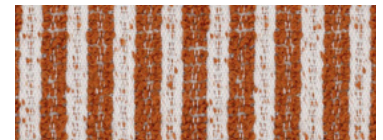

S7C. Mattone



S7D. Bosco

Symi
Outdoor (Cat. 3)



P4P. Beige

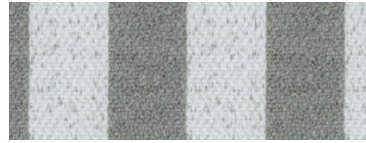

P4M. Grigio

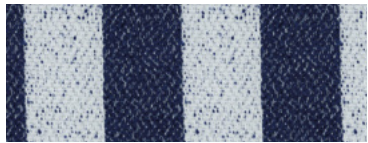

P4L. Blu

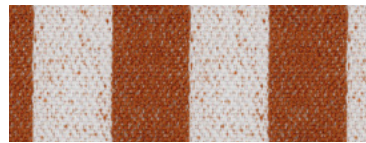

P4N. Mattone

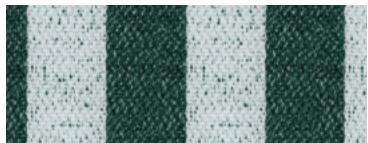

P4K. Bosco

Selva
Outdoor (Cat. 4)



E9A. Red orange



E9B. Beige



E9C. Grey blue



E9D. White blue

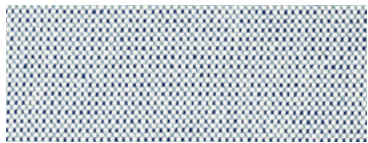

E9E. Bluettes

Soul
Outdoor (Cat. 4)

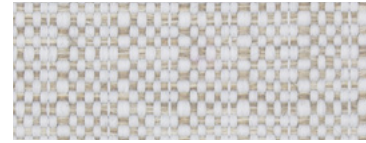

ZU. Panna



ZT. Nocciola

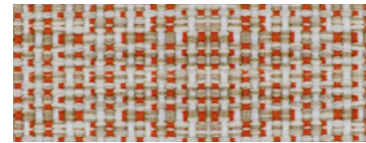

ZK. Arancio

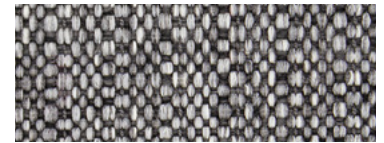

ZV. Grigio



T1M. Nero melange

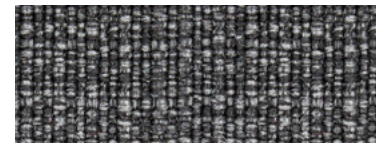

ZW. Nero

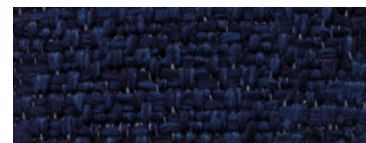

T1N. Blu

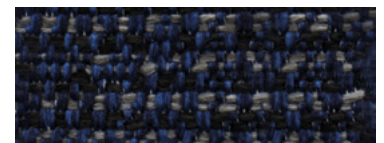

T1Q. Blu melange

Summer
Outdoor (Cat. 4)



B6A. Bianco



B6B. Avorio



B6N. Terra



B6D. Cipria



B6E. Grigio



B6F. Sale e pepe



B6I. Corniola



B6Q. Terra di siena

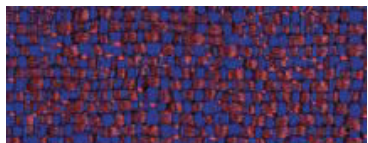

B6M. Red-blue



B6R. Azzurro

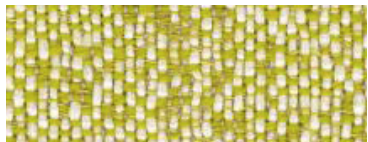

B6K. Alga



B6T. Limone

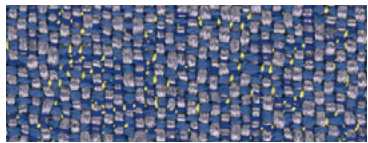

B6U. Glicine

Sunset
Outdoor (Cat. 4)



T1A. Panna

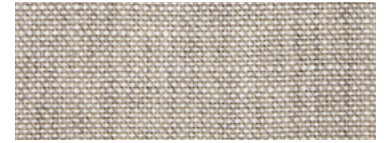

T1B. Beige chiaro



T1C. Beige



T1I. Nocciola



T1E. Light blue

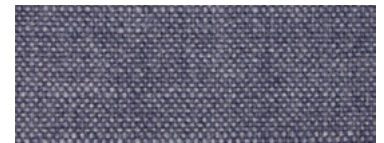

T1F. Blu



T1L. Cielo

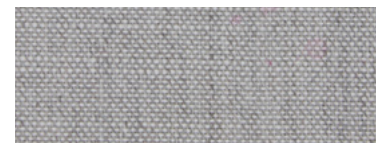

T1G. Grigio



T1K. Antracite

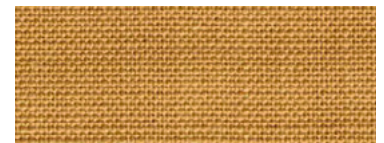

T1R. Senape

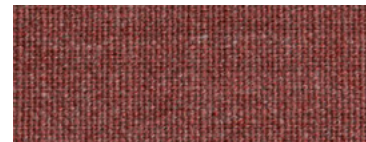

T1S. Terracotta



T1T. Viola



T1U. Muschio

POTOCOCCO

Via Indipendenza 4
33044 - Manzano, Udine - Italy
T. +39 0432 745111
© 2026 Potocco S.p.A.
info@potocco.it

Potocco USA
Hickory, NC 28602
United States of America
customerservice@potocco-usa.com



Concept and Art Direction
Rodolfo Agrella — RADS

Project Coordination
Potocco Marketing Team

Poetry Excerpts by
Luciano Morandini ^{1 2 3}

Historical Images
Archivio Potocco

Product Images
Superresolution

Copy
CORA-PR

Printing
Grafiche Filacorda

1 "All'alba"
L. Morandini,
Camminando Camminando, Campanotto, 2004.

2 L. Morandini,
Dalle botteghe del vino, Aviani,
1971.
pp. 23-24

3 L. Morandini,
Dalle botteghe del vino, Aviani,
1971.
pp. 46

Potocco reserves the right to introduce any changes to its own models without prior notice. Color tones may vary from one dye lot to another.

© 2026 by Potocco S.p.A.
All rights reserved



The mark of
responsible forestry
"Richiedi i nostri
prodotti certificati
FSC®"

potocco.it

Concept and Art Direction
Roberto Agella — RADA2

Project Coordination
Potocco Marketing Team

Poetry Excerpts by
Luciano Morandini 1 2 3

Historical Images
Archivio Potocco

Product Images
Superresolution

Copy
COA-PR

Printing
Grafiche Filacorda

1

2

3

1

“All'alba”
L. Morandini,
Camminando Camminando, Campanotto, 2004.

2

L. Morandini,
Dalle botteghe del vino, Aviani,
1971.
pp. 23-24

3

L. Morandini,
Dalle botteghe del vino, Aviani,
1971.
pp. 46

About this Catalogue-Object

Concepito come un oggetto editoriale, questo volume incarna l'eredità di Potocco, la sua maestria artigianale e una visione proiettata al futuro. Le sue 292 pagine sono organizzate in fascicoli da 12 e 8 pagine, cuciti a mano con filo nero, a rivelare e celebrare la propria costruzione. Gli interni combinano Fedrigoni Freelife Vellum White 100 g, stampata in quadricromia fronte-retro, con Polyedra Satin Plus Translucent 100 g, serigrafata in un colore. La tipografia affianca le famiglie Garamond Premier Pro e Moderat, in equilibrio tra sensibilità classica e contemporanea. La copertina e le alette, in Fedrigoni Freelife Vellum White 260 g, rivestite con tessuto Renkalik nella tonalità Savanna e rifinite con stampa a caldo bianca, rafforzano i valori di profondità materica e lusso discrete di Potocco.

Conceived as a crafted editorial object, this volume embodies Potocco's heritage, craftsmanship, and forward-looking vision. Its 292 pages are organized into 12- and 8-page booklets, hand-stitched with black binding thread to reveal and celebrate its construction. The interiors combine Fedrigoni Freelife Vellum White 100 g, four-color printed on both sides, with Polyedra Satin Plus Translucent 100 g, silkscreened in one color. Typography pairs Garamond Premier Pro with Moderat Families, balancing classical and contemporary sensitivities. The cover and flaps, in Fedrigoni Freelife Vellum White 260 g, treated with Renkalik fabric in Savanna tone and finished with white hot-foil stamping, reinforce Potocco's values of material depth and understated luxury.

1 "sdl's'llA"
L. Moirandini,
Camminando Camminando, Camminando, 2004.

2 L. Moirandini,
Dalle potette del vino, Aviani,
1971.
pp. 23-24

3 L. Moirandini,
Dalle potette del vino, Aviani,
1971.
pp. 46

About this Catalogue-Object

Concepito come un oggetto editoriale, questo volume incarna l'eredità di Potocco, la sua maestria artigianale e una visione proiettata al futuro. Le sue 292 pagine sono organizzate in fascicoli da 12 e 8 pagine, cuciti a mano con filo nero, a rivelare e celebrare la propria costruzione. Gli interni combinano Fedrigoni Freelife Vellum White 100 g, stampata in quadricromia fronte-retro, con Polyedra Satin Plus Translucent 100 g, serigrafata in un colore. La tipografia affianca le famiglie Garamond Premier Pro e Moderat, in equilibrio tra sensibilità classica e contemporanea. La copertina e le alette, in Fedrigoni Freelife Vellum White 260 g, rivestite con tessuto Renkalik nella tonalità Savanna e rifinite con stampa a caldo bianca, rafforzano i valori di profondità materica e lusso discrete di Potocco.

Conceived as a crafted editorial object, this volume embodies Potocco's heritage, craftsmanship, and forward-looking vision. Its 292 pages are organized into 12- and 8-page booklets, hand-stitched with black binding thread to reveal and celebrate its construction. The interiors combine Fedrigoni Freelife Vellum White 100 g, four-color printed on both sides, with Polyedra Satin Plus Translucent 100 g, silkscreened in one color. Typography pairs Garamond Premier Pro with Moderat Families, balancing classical and contemporary sensitivities. The cover and flaps, in Fedrigoni Freelife Vellum White 260 g, treated with Renkalik fabric in Savanna tone and finished with white hot-foiling, reinforce Potocco's values of material depth and understated luxury.

potocco.it

Conceived as a crafted editorial object, this volume embodies Potocco's heritage, craftsmanship, and forward-looking vision. Its 292 pages are organized into 12- and 8-page booklets, hand-stitched with black binding thread to reveal and celebrate its construction. The interiors combine Fedrigoni Vellum White 100 g, four-color printed on both sides, with Polyedra Satin Plus Translucent 100 g, silk-screened in one color. Typographic pairs Garamond Premier Pro with Modern Families, balancing classical and contemporary sensitivities. The cover and flaps, in Fedrigoni Vellum White 200 g, treated with Renkalk fabric in Savanna tone and finished with white hot-foil stamping, reinforce Potocco's values of material depth and understated luxury.

Concepito come un oggetto editoriale, questo volume incorpora l'eredità di Potocco, la sua maestria artigianale e una visione proiettata al futuro. Le sue 292 pagine sono organizzate in fascicoli da 12 e 8 pagine, cuciti a mano con filo nero, a rivelare e celebrare la propria costruzione. Gli interni combinano Fedrigoni Vellum White 100 g, stampata in quadricromia fronte-retro, con Polyedra Satin Plus Translucent 100 g, serigrafata in un colore. La tipografia fa affianca le famiglie Garamond Premier Pro e Moderna. La sensibilità tra classicità e contemporaneità. La copertina e le alette, in Fedrigoni Vellum White 200 g, rivestite con tessuto Renkalk nella tonalità Savanna e rifinite con stampa a caldo bianca, rafforzano i valori di profondità materica e lusso discreto di Potocco.

Una storia fatta di materia,
tempo e visione, che continua
oltre queste pagine.

A story shaped by material,
time, and vision — one that
continues beyond these pages.

